

## Very low drop voltage regulators with inhibit

### Features

- Very low dropout voltage (0.2 V typ)
- Very low quiescent current (typ. 50  $\mu$ A in OFF MODE, 0.5 mA in ON MODE, no load)
- Output current up to 100 mA
- Output voltages of 1.25; 2.5; 2.7; 3; 3.3; 3.5; 4; 4.5; 4.7; 5; 5.5; 8 V
- Internal current and thermal limit
- Only 2.2  $\mu$ F for stability
- Available in  $\pm 1\%$  (A) or  $\pm 2\%$  (C) selection at 25  $^{\circ}$ C
- Supply voltage rejection: 80db (typ.)
- Temperature range: -40 to 125  $^{\circ}$ C

### Description

The LExxAB and LExxC are very low drop voltage regulators available in SO-8 and TO-92 packages and in a wide range of output voltages.

The very low drop voltage (0.2 V) and the very low quiescent current make them particularly suitable for low noise low power applications and specially in battery powered systems.

They are pin to pin compatible with the older L78Lxx series. Furthermore in the 8 pin configuration (SO-8) they employ a shutdown logic control (pin 5, TTL compatible). This means that when the device is used as a local regulator,

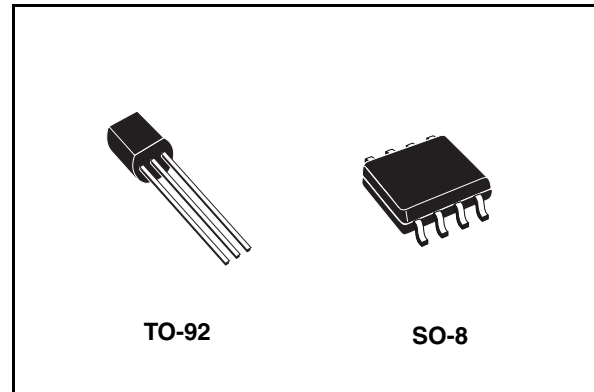

it's possible to put in stand by a part of the board even more decreasing the total power consumption. In the three terminal configuration (TO-92) the device is even in ON STATE, maintaining the same electrical performances. It needs only 2.2  $\mu$ F capacitor for stability allowing room and cost saving effect.

**Table 1. Device summary**

Part numbers		
LE12C	LE35C	LE50C
LE25AB	LE35AB	LE50AB
LE27AB	LE40C	LE55C
LE30C	LE45C	LE80C
LE33C	LE45AB	LE80AB
LE33AB	LE47AB	

# Contents

1	Diagram .....	5
2	Pin configuration .....	6
3	Maximum ratings .....	7
4	Electrical characteristics .....	8
5	Typical performance characteristics .....	30
6	Package mechanical data .....	33
7	Order codes .....	38
8	Revision history .....	39

## List of figures

Figure 1.	Block diagram . . . . .	5
Figure 2.	Pin connections (top view for SO-8, bottom view for TO-92) . . . . .	6
Figure 3.	Test circuit . . . . .	7
Figure 4.	Dropout voltage vs output current. . . . .	30
Figure 5.	Dropout voltage vs temperature . . . . .	30
Figure 6.	Supply current vs temperature . . . . .	30
Figure 7.	Supply current vs input voltage. . . . .	30
Figure 8.	Short circuit current vs dropout voltage . . . . .	30
Figure 9.	S.V.R. vs frequency . . . . .	30
Figure 10.	Logic controlled precision 3.3/5.0 V selectable output . . . . .	31
Figure 11.	Sequential multi-output supply . . . . .	31
Figure 12.	Multiple supply with ON/OFF toggle switch . . . . .	32
Figure 13.	Basic inhibit functions . . . . .	32

## List of tables

Table 1.	Device summary . . . . .	1
Table 2.	Absolute maximum ratings . . . . .	7
Table 3.	Thermal data . . . . .	7
Table 4.	Electrical characteristics for LE12AB (refer to the test circuits, $T_J = 25^\circ\text{C}$ , $C_I = 0.1 \mu\text{F}$ , $C_O = 2.2 \mu\text{F}$ unless otherwise specified.) . . . . .	8
Table 5.	Electrical characteristics for LE12C (refer to the test circuits, $T_J = 25^\circ\text{C}$ , $C_I = 0.1 \mu\text{F}$ , $C_O = 2.2 \mu\text{F}$ unless otherwise specified.) . . . . .	9
Table 6.	Electrical characteristics for LE25AB (refer to the test circuits, $T_J = 25^\circ\text{C}$ , $C_I = 0.1 \mu\text{F}$ , $C_O = 2.2 \mu\text{F}$ unless otherwise specified.) . . . . .	10
Table 7.	Electrical characteristics for LE25C (refer to the test circuits, $T_J = 25^\circ\text{C}$ , $C_I = 0.1 \mu\text{F}$ , $C_O = 2.2 \mu\text{F}$ unless otherwise specified.) . . . . .	11
Table 8.	Electrical characteristics for LE27AB (refer to the test circuits, $T_J = 25^\circ\text{C}$ , $C_I = 0.1 \mu\text{F}$ , $C_O = 2.2 \mu\text{F}$ unless otherwise specified.) . . . . .	12
Table 9.	Electrical characteristics for LE27C (refer to the test circuits, $T_J = 25^\circ\text{C}$ , $C_I = 0.1 \mu\text{F}$ , $C_O = 2.2 \mu\text{F}$ unless otherwise specified.) . . . . .	13
Table 10.	Electrical characteristics for LE30AB (refer to the test circuits, $T_J = 25^\circ\text{C}$ , $C_I = 0.1 \mu\text{F}$ , $C_O = 2.2 \mu\text{F}$ unless otherwise specified.) . . . . .	14
Table 11.	Electrical characteristics for LE30C (refer to the test circuits, $T_J = 25^\circ\text{C}$ , $C_I = 0.1 \mu\text{F}$ , $C_O = 2.2 \mu\text{F}$ unless otherwise specified.) . . . . .	15
Table 12.	Electrical characteristics for LE33AB (refer to the test circuits, $T_J = 25^\circ\text{C}$ , $C_I = 0.1 \mu\text{F}$ , $C_O = 2.2 \mu\text{F}$ unless otherwise specified.) . . . . .	16
Table 13.	Electrical characteristics for LE33C (refer to the test circuits, $T_J = 25^\circ\text{C}$ , $C_I = 0.1 \mu\text{F}$ , $C_O = 2.2 \mu\text{F}$ unless otherwise specified.) . . . . .	17
Table 14.	Electrical characteristics for LE35AB (refer to the test circuits, $T_J = 25^\circ\text{C}$ , $C_I = 0.1 \mu\text{F}$ , $C_O = 2.2 \mu\text{F}$ unless otherwise specified.) . . . . .	18
Table 15.	Electrical characteristics for LE35C (refer to the test circuits, $T_J = 25^\circ\text{C}$ , $C_I = 0.1 \mu\text{F}$ , $C_O = 2.2 \mu\text{F}$ unless otherwise specified.) . . . . .	19
Table 16.	Electrical characteristics for LE40AB (refer to the test circuits, $T_J = 25^\circ\text{C}$ , $C_I = 0.1 \mu\text{F}$ , $C_O = 2.2 \mu\text{F}$ unless otherwise specified.) . . . . .	20
Table 17.	Electrical characteristics for LE40C (refer to the test circuits, $T_J = 25^\circ\text{C}$ , $C_I = 0.1 \mu\text{F}$ , $C_O = 2.2 \mu\text{F}$ unless otherwise specified.) . . . . .	21
Table 18.	Electrical characteristics for LE45AB (refer to the test circuits, $T_J = 25^\circ\text{C}$ , $C_I = 0.1 \mu\text{F}$ , $C_O = 2.2 \mu\text{F}$ unless otherwise specified.) . . . . .	22
Table 19.	Electrical characteristics for LE45C (refer to the test circuits, $T_J = 25^\circ\text{C}$ , $C_I = 0.1 \mu\text{F}$ , $C_O = 2.2 \mu\text{F}$ unless otherwise specified.) . . . . .	23
Table 20.	Electrical characteristics for LE47AB (refer to the test circuits, $T_J = 25^\circ\text{C}$ , $C_I = 0.1 \mu\text{F}$ , $C_O = 2.2 \mu\text{F}$ unless otherwise specified.) . . . . .	24
Table 21.	Electrical characteristics for LE47C (refer to the test circuits, $T_J = 25^\circ\text{C}$ , $C_I = 0.1 \mu\text{F}$ , $C_O = 2.2 \mu\text{F}$ unless otherwise specified.) . . . . .	25
Table 22.	Electrical characteristics for LE50AB (refer to the test circuits, $T_J = 25^\circ\text{C}$ , $C_I = 0.1 \mu\text{F}$ , $C_O = 2.2 \mu\text{F}$ unless otherwise specified.) . . . . .	26
Table 23.	Electrical characteristics for LE50C (refer to the test circuits, $T_J = 25^\circ\text{C}$ , $C_I = 0.1 \mu\text{F}$ , $C_O = 2.2 \mu\text{F}$ unless otherwise specified.) . . . . .	27
Table 24.	Electrical characteristics for LE80AB (refer to the test circuits, $T_J = 25^\circ\text{C}$ , $C_I = 0.1 \mu\text{F}$ , $C_O = 2.2 \mu\text{F}$ unless otherwise specified.) . . . . .	28
Table 25.	Electrical characteristics for LE80C (refer to the test circuits, $T_J = 25^\circ\text{C}$ , $C_I = 0.1 \mu\text{F}$ , $C_O = 2.2 \mu\text{F}$ unless otherwise specified.) . . . . .	29
Table 27.	Document revision history . . . . .	39

# 1 Diagram

Figure 1. Block diagram

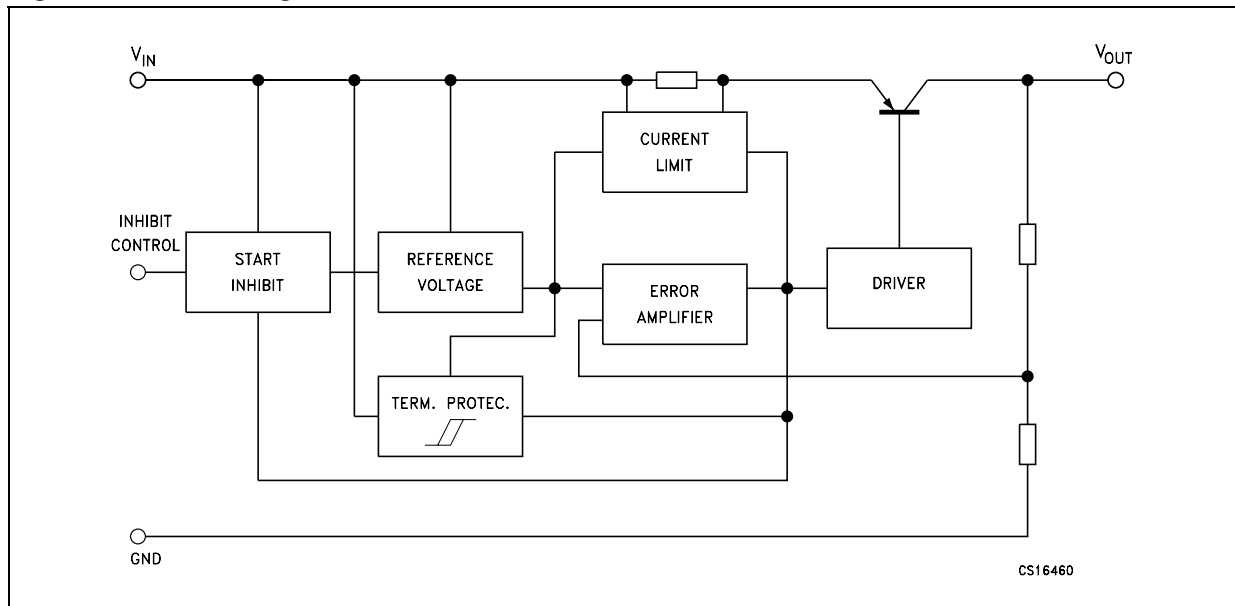

## 2 Pin configuration

Figure 2. Pin connections (top view for SO-8, bottom view for TO-92)

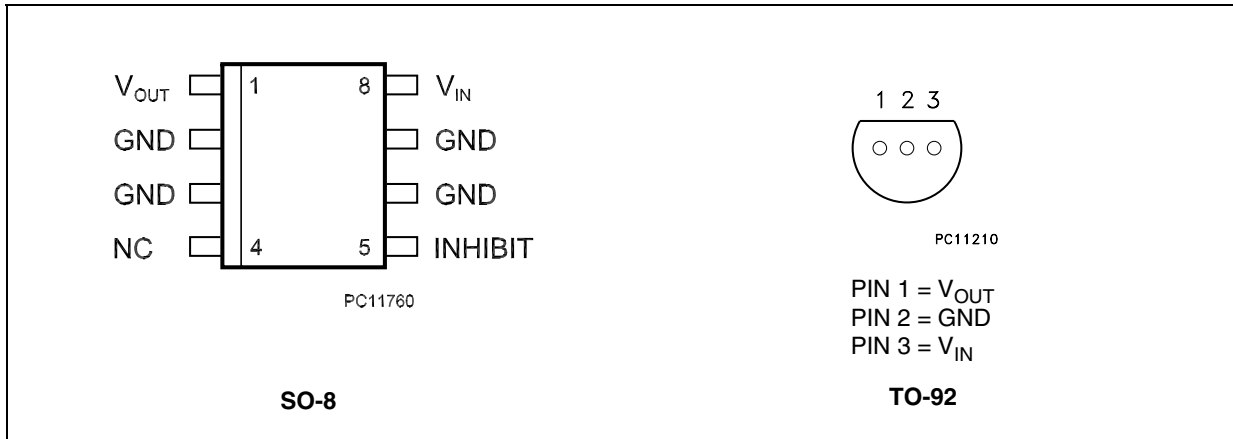

### 3 Maximum ratings

**Table 2. Absolute maximum ratings**

Symbol	Parameter	Value	Unit
$V_I$	DC input voltage	20	V
$I_O$	Output current	Internally Limited <sup>(1)</sup>	
$P_{TOT}$	Power dissipation	Internally Limited	
$T_{STG}$	Storage temperature range	-65 to 150	°C
$T_{OP}$	Operating junction temperature range	-40 to 125	°C

1. Our SO-8 package used for Voltage Regulators is modified internally to have pins 2, 3, 6 and 7 electrically communed to the die attach flag. This particular frame decreases the total thermal resistance of the package and increases its ability to dissipate power when an appropriate area of copper on the printed circuit board is available for heatsinking. The external dimensions are the same as for the standard SO-8.

**Table 3. Thermal data**

Symbol	Parameter	SO-8	TO-92	Unit
$R_{thJC}$	Thermal resistance junction-case	20		°C/W
$R_{thJA}$	Thermal resistance junction-ambient	55	200	°C/W

**Figure 3. Test circuit**

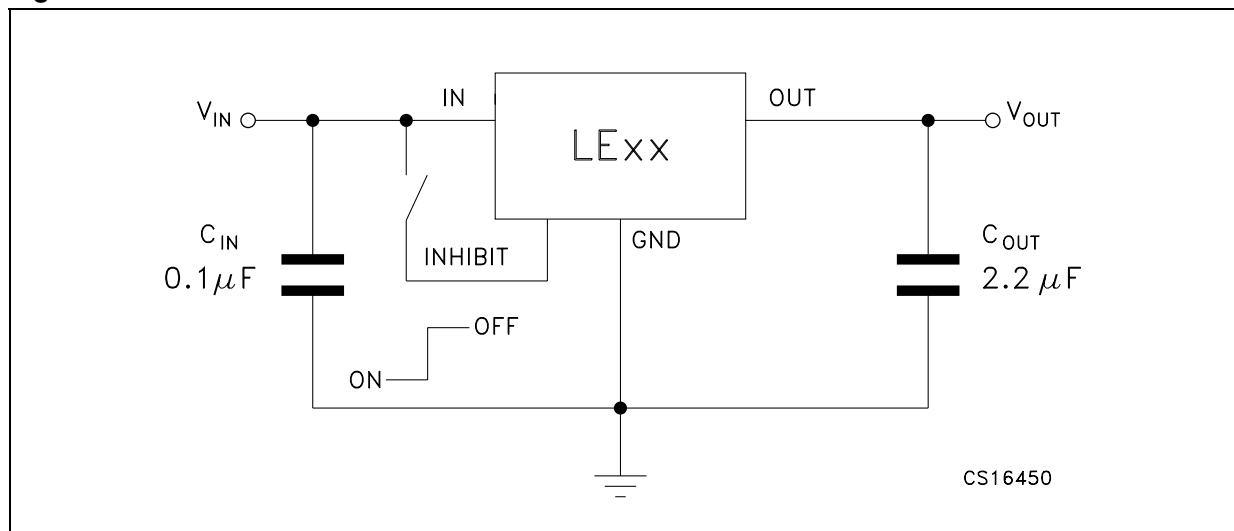

**Note:** *If the Inhibit pin is left floating, the regulator is in ON mode. However, to avoid any noise picking-up, it is suggested to ground it when the Inhibit function is not used.*

## 4 Electrical characteristics

**Table 4. Electrical characteristics for LE12AB** (refer to the test circuits,  $T_J = 25^\circ\text{C}$ ,  $C_I = 0.1 \mu\text{F}$ ,  $C_O = 2.2 \mu\text{F}$  unless otherwise specified.)

Symbol	Parameter	Test conditions	Min.	Typ.	Max.	Unit
$V_O$	Output voltage	$I_O = 10 \text{ mA}$ , $V_I = 3.3 \text{ V}$	1.225	1.25	1.275	V
		$I_O = 10 \text{ mA}$ , $V_I = 3.3 \text{ V}$ , $T_A = -25 \text{ to } 85^\circ\text{C}$	1.2		1.3	
$V_I$	Operating input voltage	$I_O = 100 \text{ mA}$	2.5		18	V
$I_O$	Output current limit		150			mA
$\Delta V_O$	Line regulation	$V_I = 2.5 \text{ to } 18 \text{ V}$ , $I_O = 0.5 \text{ mA}$		3	15	mV
$\Delta V_O$	Load regulation	$V_I = 2.8 \text{ V}$ , $I_O = 0.5 \text{ to } 100 \text{ mA}$		3	15	mV
$I_d$	Quiescent current	$V_I = 2.5 \text{ to } 18 \text{ V}$ , $I_O = 0 \text{ mA}$	ON MODE	0.5	1	mA
		$V_I = 2.5 \text{ to } 18 \text{ V}$ , $I_O = 100 \text{ mA}$		1.5	3	
		$V_I = 6 \text{ V}$	OFF MODE	50	100	$\mu\text{A}$
SVR	Supply voltage rejection	$I_O = 5 \text{ mA}$ , $V_I = 3.5 \pm 1 \text{ V}$	$f = 120 \text{ Hz}$	82		dB
			$f = 1 \text{ kHz}$	77		
			$f = 10 \text{ kHz}$	60		
eN	Output noise voltage	$B = 10 \text{ Hz to } 100 \text{ kHz}$		50		$\mu\text{V}$
$V_d$	Dropout voltage	$I_O = 100 \text{ mA}$ , $T_A = -40 \text{ to } 125^\circ\text{C}$		1.25		V
$V_{IL}$	Control input logic low	$T_A = -40 \text{ to } 125^\circ\text{C}$			0.8	V
$V_{IH}$	Control input logic high	$T_A = -40 \text{ to } 125^\circ\text{C}$	2			V
$I_I$	Control input current	$V_I = 6 \text{ V}$ , $V_C = 6 \text{ V}$		10		$\mu\text{A}$
$C_O$	Output bypass capacitance	$\text{ESR} = 0.1 \text{ to } 10 \Omega$ , $I_O = 0 \text{ to } 100 \text{ mA}$	2	10		$\mu\text{F}$



**Table 5. Electrical characteristics for LE12C** (refer to the test circuits,  $T_J = 25^\circ\text{C}$ ,  $C_I = 0.1 \mu\text{F}$ ,  $C_O = 2.2 \mu\text{F}$  unless otherwise specified.)

Symbol	Parameter	Test conditions	Min.	Typ.	Max.	Unit	
$V_O$	Output voltage	$I_O = 10 \text{ mA}$ , $V_I = 3.3 \text{ V}$	1.225	1.25	1.275	V	
		$I_O = 10 \text{ mA}$ , $V_I = 3.3 \text{ V}$ , $T_A = -25 \text{ to } 85^\circ\text{C}$	1.2		1.3		
$V_I$	Operating input voltage	$I_O = 100 \text{ mA}$	2.5		18	V	
$I_O$	Output current limit		150			mA	
$\Delta V_O$	Line regulation	$V_I = 2.5 \text{ to } 18 \text{ V}$ , $I_O = 0.5 \text{ mA}$		3	20	mV	
$\Delta V_O$	Load regulation	$V_I = 2.8 \text{ V}$ , $I_O = 0.5 \text{ to } 100 \text{ mA}$		3	25	mV	
$I_d$	Quiescent current	$V_I = 2.5 \text{ to } 18 \text{ V}$ , $I_O = 0 \text{ mA}$	ON MODE		0.5	1	mA
		$V_I = 2.5 \text{ to } 18 \text{ V}$ , $I_O = 100 \text{ mA}$			1.5	3	
		$V_I = 6 \text{ V}$	OFF MODE		50	100	$\mu\text{A}$
SVR	Supply voltage rejection	$I_O = 5 \text{ mA}$ , $V_I = 3.5 \pm 1 \text{ V}$	$f = 120 \text{ Hz}$		82	dB	
			$f = 1 \text{ kHz}$		77		
			$f = 10 \text{ kHz}$		60		
eN	Output noise voltage	$B = 10 \text{ Hz to } 100 \text{ kHz}$		50		$\mu\text{V}$	
$V_d$	Dropout voltage	$I_O = 100 \text{ mA}$ , $T_A = -40 \text{ to } 125^\circ\text{C}$		1.25		V	
$V_{IL}$	Control input logic low	$T_A = -40 \text{ to } 125^\circ\text{C}$			0.8	V	
$V_{IH}$	Control input logic high	$T_A = -40 \text{ to } 125^\circ\text{C}$	2			V	
$I_I$	Control input current	$V_I = 6 \text{ V}$ , $V_C = 6 \text{ V}$		10		$\mu\text{A}$	
$C_O$	Output bypass capacitance	$\text{ESR} = 0.1 \text{ to } 10 \Omega$ , $I_O = 0 \text{ to } 100 \text{ mA}$	2	10		$\mu\text{F}$	

**Table 6. Electrical characteristics for LE25AB** (refer to the test circuits,  $T_J = 25^\circ\text{C}$ ,  $C_I = 0.1 \mu\text{F}$ ,  $C_O = 2.2 \mu\text{F}$  unless otherwise specified.)

Symbol	Parameter	Test conditions	Min.	Typ.	Max.	Unit	
$V_O$	Output voltage	$I_O = 10 \text{ mA}$ , $V_I = 4.5 \text{ V}$	2.475	2.5	2.525	V	
		$I_O = 10 \text{ mA}$ , $V_I = 4.5 \text{ V}$ , $T_A = -25 \text{ to } 85^\circ\text{C}$	2.45		2.55		
$V_I$	Operating input voltage	$I_O = 100 \text{ mA}$			18	V	
$I_O$	Output current limit		150			mA	
$\Delta V_O$	Line regulation	$V_I = 3.2 \text{ to } 18 \text{ V}$ , $I_O = 0.5 \text{ mA}$		3	15	mV	
$\Delta V_O$	Load regulation	$V_I = 3.5 \text{ V}$ , $I_O = 0.5 \text{ to } 100 \text{ mA}$		3	15	mV	
$I_d$	Quiescent current	$V_I = 3.5 \text{ to } 18 \text{ V}$ , $I_O = 0 \text{ mA}$	ON MODE		0.5	1	mA
		$V_I = 3.5 \text{ to } 18 \text{ V}$ , $I_O = 100 \text{ mA}$			1.5	3	
		$V_I = 6 \text{ V}$	OFF MODE		50	100	$\mu\text{A}$
SVR	Supply voltage rejection	$I_O = 5 \text{ mA}$ , $V_I = 4.5 \pm 1 \text{ V}$	$f = 120 \text{ Hz}$		82	dB	
			$f = 1 \text{ kHz}$		77		
			$f = 10 \text{ kHz}$		60		
eN	Output noise voltage	$B = 10 \text{ Hz to } 100 \text{ kHz}$		50		$\mu\text{V}$	
$V_d$	Dropout voltage	$I_O = 100 \text{ mA}$		0.2	0.4	V	
		$I_O = 100 \text{ mA}$ , $T_A = -40 \text{ to } 125^\circ\text{C}$			0.5		
$V_{IL}$	Control input logic low	$T_A = -40 \text{ to } 125^\circ\text{C}$			0.8	V	
$V_{IH}$	Control input logic high	$T_A = -40 \text{ to } 125^\circ\text{C}$	2			V	
$I_I$	Control input current	$V_I = 6 \text{ V}$ , $V_C = 6 \text{ V}$		10		$\mu\text{A}$	
$C_O$	Output bypass capacitance	$\text{ESR} = 0.1 \text{ to } 10 \Omega$ , $I_O = 0 \text{ to } 100 \text{ mA}$	2	10		$\mu\text{F}$	

**Table 7. Electrical characteristics for LE25C** (refer to the test circuits,  $T_J = 25^\circ\text{C}$ ,  $C_I = 0.1 \mu\text{F}$ ,  $C_O = 2.2 \mu\text{F}$  unless otherwise specified.)

Symbol	Parameter	Test conditions	Min.	Typ.	Max.	Unit	
$V_O$	Output voltage	$I_O = 10 \text{ mA}$ , $V_I = 4.5 \text{ V}$	2.45	2.5	2.55	V	
		$I_O = 10 \text{ mA}$ , $V_I = 4.5 \text{ V}$ , $T_A = -25 \text{ to } 85^\circ\text{C}$	2.4		2.6		
$V_I$	Operating input voltage	$I_O = 100 \text{ mA}$			18	V	
$I_O$	Output current limit		150			mA	
$\Delta V_O$	Line regulation	$V_I = 3.2 \text{ to } 18 \text{ V}$ , $I_O = 0.5 \text{ mA}$		3	20	mV	
$\Delta V_O$	Load regulation	$V_I = 3.5 \text{ V}$ , $I_O = 0.5 \text{ to } 100 \text{ mA}$		3	25	mV	
$I_d$	Quiescent current	$V_I = 3.5 \text{ to } 18 \text{ V}$ , $I_O = 0 \text{ mA}$	ON MODE		0.5	1	mA
		$V_I = 3.5 \text{ to } 18 \text{ V}$ , $I_O = 100 \text{ mA}$			1.5	3	
		$V_I = 6 \text{ V}$	OFF MODE		50	100	$\mu\text{A}$
SVR	Supply voltage rejection	$I_O = 5 \text{ mA}$ , $V_I = 4.5 \pm 1 \text{ V}$	$f = 120 \text{ Hz}$		82	dB	
			$f = 1 \text{ kHz}$		77		
			$f = 10 \text{ kHz}$		60		
eN	Output noise voltage	$B = 10 \text{ Hz to } 100 \text{ kHz}$		50		$\mu\text{V}$	
$V_d$	Dropout voltage	$I_O = 100 \text{ mA}$		0.2	0.4	V	
		$I_O = 100 \text{ mA}$ , $T_A = -40 \text{ to } 125^\circ\text{C}$			0.5		
$V_{IL}$	Control input logic low	$T_A = -40 \text{ to } 125^\circ\text{C}$			0.8	V	
$V_{IH}$	Control input logic high	$T_A = -40 \text{ to } 125^\circ\text{C}$	2			V	
$I_I$	Control input current	$V_I = 6 \text{ V}$ , $V_C = 6 \text{ V}$		10		$\mu\text{A}$	
$C_O$	Output bypass capacitance	$\text{ESR} = 0.1 \text{ to } 10 \Omega$ , $I_O = 0 \text{ to } 100 \text{ mA}$	2	10		$\mu\text{F}$	

**Table 8. Electrical characteristics for LE27AB** (refer to the test circuits,  $T_J = 25^\circ\text{C}$ ,  $C_I = 0.1 \mu\text{F}$ ,  $C_O = 2.2 \mu\text{F}$  unless otherwise specified.)

Symbol	Parameter	Test conditions	Min.	Typ.	Max.	Unit	
$V_O$	Output voltage	$I_O = 10 \text{ mA}$ , $V_I = 4.7 \text{ V}$	2.673	2.7	2.727	V	
		$I_O = 10 \text{ mA}$ , $V_I = 4.7 \text{ V}$ , $T_A = -25 \text{ to } 85^\circ\text{C}$	2.646		2.754		
$V_I$	Operating input voltage	$I_O = 100 \text{ mA}$			18	V	
$I_O$	Output current limit		150			mA	
$\Delta V_O$	Line regulation	$V_I = 3.4 \text{ to } 18 \text{ V}$ , $I_O = 0.5 \text{ mA}$		3	15	mV	
$\Delta V_O$	Load regulation	$V_I = 3.7 \text{ V}$ , $I_O = 0.5 \text{ to } 100 \text{ mA}$		3	15	mV	
$I_d$	Quiescent current	$V_I = 3.7 \text{ to } 18 \text{ V}$ , $I_O = 0 \text{ mA}$	ON MODE		0.5	1	mA
		$V_I = 3.7 \text{ to } 18 \text{ V}$ , $I_O = 100 \text{ mA}$			1.5	3	
		$V_I = 6 \text{ V}$	OFF MODE		50	100	$\mu\text{A}$
SVR	Supply voltage rejection	$I_O = 5 \text{ mA}$ , $V_I = 4.7 \pm 1 \text{ V}$	$f = 120 \text{ Hz}$		82	dB	
			$f = 1 \text{ kHz}$		77		
			$f = 10 \text{ kHz}$		60		
eN	Output noise voltage	$B = 10 \text{ Hz to } 100 \text{ kHz}$		50		$\mu\text{V}$	
$V_d$	Dropout voltage	$I_O = 100 \text{ mA}$		0.2	0.4	V	
		$I_O = 100 \text{ mA}$ , $T_A = -40 \text{ to } 125^\circ\text{C}$			0.5		
$V_{IL}$	Control input logic low	$T_A = -40 \text{ to } 125^\circ\text{C}$			0.8	V	
$V_{IH}$	Control input logic high	$T_A = -40 \text{ to } 125^\circ\text{C}$	2			V	
$I_I$	Control input current	$V_I = 6 \text{ V}$ , $V_C = 6 \text{ V}$		10		$\mu\text{A}$	
$C_O$	Output bypass capacitance	$\text{ESR} = 0.1 \text{ to } 10 \Omega$ , $I_O = 0 \text{ to } 100 \text{ mA}$	2	10		$\mu\text{F}$	

**Table 9. Electrical characteristics for LE27C** (refer to the test circuits,  $T_J = 25^\circ\text{C}$ ,  $C_I = 0.1 \mu\text{F}$ ,  $C_O = 2.2 \mu\text{F}$  unless otherwise specified.)

Symbol	Parameter	Test conditions	Min.	Typ.	Max.	Unit	
$V_O$	Output voltage	$I_O = 10 \text{ mA}$ , $V_I = 4.7 \text{ V}$	2.646	2.7	2.754	V	
		$I_O = 10 \text{ mA}$ , $V_I = 4.7 \text{ V}$ , $T_A = -25 \text{ to } 85^\circ\text{C}$	2.592		2.808		
$V_I$	Operating input voltage	$I_O = 100 \text{ mA}$			18	V	
$I_O$	Output current limit		150			mA	
$\Delta V_O$	Line regulation	$V_I = 3.4 \text{ to } 18 \text{ V}$ , $I_O = 0.5 \text{ mA}$		3	20	mV	
$\Delta V_O$	Load regulation	$V_I = 3.7 \text{ V}$ , $I_O = 0.5 \text{ to } 100 \text{ mA}$		3	25	mV	
$I_d$	Quiescent current	$V_I = 3.7 \text{ to } 18 \text{ V}$ , $I_O = 0 \text{ mA}$	ON MODE		0.5	1	mA
		$V_I = 3.7 \text{ to } 18 \text{ V}$ , $I_O = 100 \text{ mA}$			1.5	3	
		$V_I = 6 \text{ V}$	OFF MODE		50	100	$\mu\text{A}$
SVR	Supply voltage rejection	$I_O = 5 \text{ mA}$ , $V_I = 4.7 \pm 1 \text{ V}$	$f = 120 \text{ Hz}$		82	dB	
			$f = 1 \text{ kHz}$		77		
			$f = 10 \text{ kHz}$		60		
eN	Output noise voltage	$B = 10 \text{ Hz to } 100 \text{ kHz}$		50		$\mu\text{V}$	
$V_d$	Dropout voltage	$I_O = 100 \text{ mA}$		0.2	0.4	V	
		$I_O = 100 \text{ mA}$ , $T_A = -40 \text{ to } 125^\circ\text{C}$			0.5		
$V_{IL}$	Control input logic low	$T_A = -40 \text{ to } 125^\circ\text{C}$			0.8	V	
$V_{IH}$	Control input logic high	$T_A = -40 \text{ to } 125^\circ\text{C}$	2			V	
$I_I$	Control input current	$V_I = 6 \text{ V}$ , $V_C = 6 \text{ V}$		10		$\mu\text{A}$	
$C_O$	Output bypass capacitance	$\text{ESR} = 0.1 \text{ to } 10 \Omega$ , $I_O = 0 \text{ to } 100 \text{ mA}$	2	10		$\mu\text{F}$	

**Table 10. Electrical characteristics for LE30AB** (refer to the test circuits,  $T_J = 25^\circ\text{C}$ ,  $C_I = 0.1 \mu\text{F}$ ,  $C_O = 2.2 \mu\text{F}$  unless otherwise specified.)

Symbol	Parameter	Test conditions	Min.	Typ.	Max.	Unit	
$V_O$	Output voltage	$I_O = 10 \text{ mA}$ , $V_I = 5 \text{ V}$	2.970	3	3.030	V	
		$I_O = 10 \text{ mA}$ , $V_I = 5 \text{ V}$ , $T_A = -25 \text{ to } 85^\circ\text{C}$	2.940		3.060		
$V_I$	Operating input voltage	$I_O = 100 \text{ mA}$			18	V	
$I_O$	Output current limit		150			mA	
$\Delta V_O$	Line regulation	$V_I = 3.7 \text{ to } 18 \text{ V}$ , $I_O = 0.5 \text{ mA}$		3	15	mV	
$\Delta V_O$	Load regulation	$V_I = 4 \text{ V}$ , $I_O = 0.5 \text{ to } 100 \text{ mA}$		3	15	mV	
$I_d$	Quiescent current	$V_I = 4 \text{ to } 18\text{V}$ , $I_O = 0\text{mA}$	ON MODE		0.5	1	mA
		$V_I = 4 \text{ to } 18\text{V}$ , $I_O = 100\text{mA}$			1.5	3	
		$V_I = 6 \text{ V}$	OFF MODE		50	100	$\mu\text{A}$
SVR	Supply voltage rejection	$I_O = 5 \text{ mA}$ , $V_I = 5 \pm 1 \text{ V}$	$f = 120 \text{ Hz}$		81	dB	
			$f = 1 \text{ kHz}$		76		
			$f = 10 \text{ kHz}$		60		
eN	Output noise voltage	$B = 10 \text{ Hz to } 100 \text{ kHz}$		50		$\mu\text{V}$	
$V_d$	Dropout voltage	$I_O = 100 \text{ mA}$		0.2	0.4	V	
		$I_O = 100 \text{ mA}$ , $T_A = -40 \text{ to } 125^\circ\text{C}$			0.5		
$V_{IL}$	Control input logic low	$T_A = -40 \text{ to } 125^\circ\text{C}$			0.8	V	
$V_{IH}$	Control input logic high	$T_A = -40 \text{ to } 125^\circ\text{C}$	2			V	
$I_I$	Control input current	$V_I = 6 \text{ V}$ , $V_C = 6 \text{ V}$		10		$\mu\text{A}$	
$C_O$	Output bypass capacitance	$\text{ESR} = 0.1 \text{ to } 10 \Omega$ , $I_O = 0 \text{ to } 100 \text{ mA}$	2	10		$\mu\text{F}$	

**Table 11. Electrical characteristics for LE30C** (refer to the test circuits,  $T_J = 25^\circ\text{C}$ ,  $C_I = 0.1 \mu\text{F}$ ,  $C_O = 2.2 \mu\text{F}$  unless otherwise specified.)

Symbol	Parameter	Test conditions	Min.	Typ.	Max.	Unit	
$V_O$	Output voltage	$I_O = 10 \text{ mA}$ , $V_I = 5 \text{ V}$	2.940	3	3.060	V	
		$I_O = 10 \text{ mA}$ , $V_I = 5 \text{ V}$ , $T_A = -25 \text{ to } 85^\circ\text{C}$	2.880		3.120		
$V_I$	Operating input voltage	$I_O = 100 \text{ mA}$			18	V	
$I_O$	Output current limit		150			mA	
$\Delta V_O$	Line regulation	$V_I = 3.7 \text{ to } 18 \text{ V}$ , $I_O = 0.5 \text{ mA}$		3	20	mV	
$\Delta V_O$	Load regulation	$V_I = 4 \text{ V}$ , $I_O = 0.5 \text{ to } 100 \text{ mA}$		3	25	mV	
$I_d$	Quiescent current	$V_I = 4 \text{ to } 18\text{V}$ , $I_O = 0\text{mA}$	ON MODE		0.5	1	mA
		$V_I = 4 \text{ to } 18\text{V}$ , $I_O = 100\text{mA}$			1.5	3	
		$V_I = 6 \text{ V}$	OFF MODE		50	100	$\mu\text{A}$
SVR	Supply voltage rejection	$I_O = 5 \text{ mA}$ , $V_I = 5 \pm 1 \text{ V}$	$f = 120 \text{ Hz}$		81	dB	
			$f = 1 \text{ kHz}$		76		
			$f = 10 \text{ kHz}$		60		
eN	Output noise voltage	$B = 10 \text{ Hz to } 100 \text{ kHz}$		50		$\mu\text{V}$	
$V_d$	Dropout voltage	$I_O = 100 \text{ mA}$		0.2	0.4	V	
		$I_O = 100 \text{ mA}$ , $T_A = -40 \text{ to } 125^\circ\text{C}$			0.5		
$V_{IL}$	Control input logic low	$T_A = -40 \text{ to } 125^\circ\text{C}$			0.8	V	
$V_{IH}$	Control input logic high	$T_A = -40 \text{ to } 125^\circ\text{C}$	2			V	
$I_I$	Control input current	$V_I = 6 \text{ V}$ , $V_C = 6 \text{ V}$		10		$\mu\text{A}$	
$C_O$	Output bypass capacitance	$\text{ESR} = 0.1 \text{ to } 10 \Omega$ , $I_O = 0 \text{ to } 100 \text{ mA}$	2	10		$\mu\text{F}$	

**Table 12. Electrical characteristics for LE33AB** (refer to the test circuits,  $T_J = 25^\circ\text{C}$ ,  $C_I = 0.1 \mu\text{F}$ ,  $C_O = 2.2 \mu\text{F}$  unless otherwise specified.)

Symbol	Parameter	Test conditions	Min.	Typ.	Max.	Unit	
$V_O$	Output voltage	$I_O = 10 \text{ mA}$ , $V_I = 5.3 \text{ V}$	3.267	3.3	3.333	V	
		$I_O = 10 \text{ mA}$ , $V_I = 5.3 \text{ V}$ , $T_A = -25 \text{ to } 85^\circ\text{C}$	3.234		3.366		
$V_I$	Operating input voltage	$I_O = 100 \text{ mA}$			18	V	
$I_O$	Output current limit		150			mA	
$\Delta V_O$	Line regulation	$V_I = 4 \text{ to } 18 \text{ V}$ , $I_O = 0.5 \text{ mA}$		3	15	mV	
$\Delta V_O$	Load regulation	$V_I = 4.3 \text{ V}$ , $I_O = 0.5 \text{ to } 100 \text{ mA}$		3	15	mV	
$I_d$	Quiescent current	$V_I = 4.3 \text{ to } 18 \text{ V}$ , $I_O = 0 \text{ mA}$	ON MODE		0.5	1	mA
		$V_I = 4.3 \text{ to } 18 \text{ V}$ , $I_O = 100 \text{ mA}$			1.5	3	
		$V_I = 6 \text{ V}$	OFF MODE		50	100	$\mu\text{A}$
SVR	Supply voltage rejection	$I_O = 5 \text{ mA}$ , $V_I = 5.3 \pm 1 \text{ V}$	$f = 120 \text{ Hz}$		80	dB	
			$f = 1 \text{ kHz}$		75		
			$f = 10 \text{ kHz}$		60		
eN	Output noise voltage	$B = 10 \text{ Hz to } 100 \text{ kHz}$		50		$\mu\text{V}$	
$V_d$	Dropout voltage	$I_O = 100 \text{ mA}$		0.2	0.4	V	
		$I_O = 100 \text{ mA}$ , $T_A = -40 \text{ to } 125^\circ\text{C}$			0.5		
$V_{IL}$	Control input logic low	$T_A = -40 \text{ to } 125^\circ\text{C}$			0.8	V	
$V_{IH}$	Control input logic high	$T_A = -40 \text{ to } 125^\circ\text{C}$	2			V	
$I_I$	Control input current	$V_I = 6 \text{ V}$ , $V_C = 6 \text{ V}$		10		$\mu\text{A}$	
$C_O$	Output bypass capacitance	$\text{ESR} = 0.1 \text{ to } 10 \Omega$ , $I_O = 0 \text{ to } 100 \text{ mA}$	2	10		$\mu\text{F}$	



**Table 13. Electrical characteristics for LE33C** (refer to the test circuits,  $T_J = 25^\circ\text{C}$ ,  $C_I = 0.1 \mu\text{F}$ ,  $C_O = 2.2 \mu\text{F}$  unless otherwise specified.)

Symbol	Parameter	Test conditions	Min.	Typ.	Max.	Unit	
$V_O$	Output voltage	$I_O = 10 \text{ mA}$ , $V_I = 5.3 \text{ V}$	3.234	3.3	3.366	V	
		$I_O = 10 \text{ mA}$ , $V_I = 5.3 \text{ V}$ , $T_A = -25 \text{ to } 85^\circ\text{C}$	3.168		3.432		
$V_I$	Operating input voltage	$I_O = 100 \text{ mA}$			18	V	
$I_O$	Output current limit		150			mA	
$\Delta V_O$	Line regulation	$V_I = 4 \text{ to } 18 \text{ V}$ , $I_O = 0.5 \text{ mA}$		3	20	mV	
$\Delta V_O$	Load regulation	$V_I = 4.3 \text{ V}$ , $I_O = 0.5 \text{ to } 100 \text{ mA}$		3	25	mV	
$I_d$	Quiescent current	$V_I = 4.3 \text{ to } 18 \text{ V}$ , $I_O = 0 \text{ mA}$	ON MODE		0.5	1	mA
		$V_I = 4.3 \text{ to } 18 \text{ V}$ , $I_O = 100 \text{ mA}$			1.5	3	
		$V_I = 6 \text{ V}$	OFF MODE		50	100	$\mu\text{A}$
SVR	Supply voltage rejection	$I_O = 5 \text{ mA}$ , $V_I = 5.3 \pm 1 \text{ V}$	$f = 120 \text{ Hz}$		80	dB	
			$f = 1 \text{ kHz}$		75		
			$f = 10 \text{ kHz}$		60		
eN	Output noise voltage	$B = 10 \text{ Hz to } 100 \text{ kHz}$		50		$\mu\text{V}$	
$V_d$	Dropout voltage	$I_O = 100 \text{ mA}$		0.2	0.4	V	
		$I_O = 100 \text{ mA}$ , $T_A = -40 \text{ to } 125^\circ\text{C}$			0.5		
$V_{IL}$	Control input logic low	$T_A = -40 \text{ to } 125^\circ\text{C}$			0.8	V	
$V_{IH}$	Control input logic high	$T_A = -40 \text{ to } 125^\circ\text{C}$	2			V	
$I_I$	Control input current	$V_I = 6 \text{ V}$ , $V_C = 6 \text{ V}$		10		$\mu\text{A}$	
$C_O$	Output bypass capacitance	$\text{ESR} = 0.1 \text{ to } 10 \Omega$ , $I_O = 0 \text{ to } 100 \text{ mA}$	2	10		$\mu\text{F}$	

**Table 14. Electrical characteristics for LE35AB** (refer to the test circuits,  $T_J = 25^\circ\text{C}$ ,  $C_I = 0.1 \mu\text{F}$ ,  $C_O = 2.2 \mu\text{F}$  unless otherwise specified.)

Symbol	Parameter	Test conditions	Min.	Typ.	Max.	Unit	
$V_O$	Output voltage	$I_O = 10 \text{ mA}$ , $V_I = 5.5 \text{ V}$	3.465	3.5	3.535	V	
		$I_O = 10 \text{ mA}$ , $V_I = 5.5 \text{ V}$ , $T_A = -25 \text{ to } 85^\circ\text{C}$	3.43		3.57		
$V_I$	Operating input voltage	$I_O = 100 \text{ mA}$			18	V	
$I_O$	Output current limit		150			mA	
$\Delta V_O$	Line regulation	$V_I = 4.2 \text{ to } 18 \text{ V}$ , $I_O = 0.5 \text{ mA}$		3	15	mV	
$\Delta V_O$	Load regulation	$V_I = 4.5 \text{ V}$ , $I_O = 0.5 \text{ to } 100 \text{ mA}$		3	15	mV	
$I_d$	Quiescent current	$V_I = 4.5 \text{ to } 18 \text{ V}$ , $I_O = 0 \text{ mA}$	ON MODE		0.5	1	mA
		$V_I = 4.5 \text{ to } 18 \text{ V}$ , $I_O = 100 \text{ mA}$			1.5	3	
		$V_I = 6 \text{ V}$	OFF MODE		50	100	$\mu\text{A}$
SVR	Supply voltage rejection	$I_O = 5 \text{ mA}$ , $V_I = 5.5 \pm 1 \text{ V}$	$f = 120 \text{ Hz}$		79	dB	
			$f = 1 \text{ kHz}$		74		
			$f = 10 \text{ kHz}$		60		
eN	Output noise voltage	$B = 10 \text{ Hz to } 100 \text{ kHz}$		50		$\mu\text{V}$	
$V_d$	Dropout voltage	$I_O = 100 \text{ mA}$		0.2	0.4	V	
		$I_O = 100 \text{ mA}$ , $T_A = -40 \text{ to } 125^\circ\text{C}$			0.5		
$V_{IL}$	Control input logic low	$T_A = -40 \text{ to } 125^\circ\text{C}$			0.8	V	
$V_{IH}$	Control input logic high	$T_A = -40 \text{ to } 125^\circ\text{C}$	2			V	
$I_I$	Control input current	$V_I = 6 \text{ V}$ , $V_C = 6 \text{ V}$		10		$\mu\text{A}$	
$C_O$	Output bypass capacitance	$\text{ESR} = 0.1 \text{ to } 10 \Omega$ , $I_O = 0 \text{ to } 100 \text{ mA}$	2	10		$\mu\text{F}$	

**Table 15. Electrical characteristics for LE35C** (refer to the test circuits,  $T_J = 25^\circ\text{C}$ ,  $C_I = 0.1 \mu\text{F}$ ,  $C_O = 2.2 \mu\text{F}$  unless otherwise specified.)

Symbol	Parameter	Test conditions	Min.	Typ.	Max.	Unit	
$V_O$	Output voltage	$I_O = 10 \text{ mA}$ , $V_I = 5.5 \text{ V}$	3.43	3.5	3.57	V	
		$I_O = 10 \text{ mA}$ , $V_I = 5.5 \text{ V}$ , $T_A = -25 \text{ to } 85^\circ\text{C}$	3.36		3.64		
$V_I$	Operating input voltage	$I_O = 100 \text{ mA}$			18	V	
$I_O$	Output current limit		150			mA	
$\Delta V_O$	Line regulation	$V_I = 4.2 \text{ to } 18 \text{ V}$ , $I_O = 0.5 \text{ mA}$		3	20	mV	
$\Delta V_O$	Load regulation	$V_I = 4.5 \text{ V}$ , $I_O = 0.5 \text{ to } 100 \text{ mA}$		3	25	mV	
$I_d$	Quiescent current	$V_I = 4.5 \text{ to } 18 \text{ V}$ , $I_O = 0 \text{ mA}$	ON MODE		0.5	1	mA
		$V_I = 4.5 \text{ to } 18 \text{ V}$ , $I_O = 100 \text{ mA}$			1.5	3	
		$V_I = 6 \text{ V}$	OFF MODE		50	100	$\mu\text{A}$
SVR	Supply voltage rejection	$I_O = 5 \text{ mA}$ , $V_I = 5.5 \pm 1 \text{ V}$	$f = 120 \text{ Hz}$		79	dB	
			$f = 1 \text{ kHz}$		74		
			$f = 10 \text{ kHz}$		60		
eN	Output noise voltage	$B = 10 \text{ Hz to } 100 \text{ kHz}$		50		$\mu\text{V}$	
$V_d$	Dropout voltage	$I_O = 100 \text{ mA}$		0.2	0.4	V	
		$I_O = 100 \text{ mA}$ , $T_A = -40 \text{ to } 125^\circ\text{C}$			0.5		
$V_{IL}$	Control input logic low	$T_A = -40 \text{ to } 125^\circ\text{C}$			0.8	V	
$V_{IH}$	Control input logic high	$T_A = -40 \text{ to } 125^\circ\text{C}$	2			V	
$I_I$	Control input current	$V_I = 6 \text{ V}$ , $V_C = 6 \text{ V}$		10		$\mu\text{A}$	
$C_O$	Output bypass capacitance	$\text{ESR} = 0.1 \text{ to } 10 \Omega$ , $I_O = 0 \text{ to } 100 \text{ mA}$	2	10		$\mu\text{F}$	

**Table 16. Electrical characteristics for LE40AB** (refer to the test circuits,  $T_J = 25^\circ\text{C}$ ,  $C_I = 0.1 \mu\text{F}$ ,  $C_O = 2.2 \mu\text{F}$  unless otherwise specified.)

Symbol	Parameter	Test conditions	Min.	Typ.	Max.	Unit	
$V_O$	Output voltage	$I_O = 10 \text{ mA}$ , $V_I = 6 \text{ V}$	3.96	4	4.04	V	
		$I_O = 10 \text{ mA}$ , $V_I = 6 \text{ V}$ , $T_A = -25 \text{ to } 85^\circ\text{C}$	3.92		4.08		
$V_I$	Operating input voltage	$I_O = 100 \text{ mA}$			18	V	
$I_O$	Output current limit		150			mA	
$\Delta V_O$	Line regulation	$V_I = 4.7 \text{ to } 18 \text{ V}$ , $I_O = 0.5 \text{ mA}$		4	20	mV	
$\Delta V_O$	Load regulation	$V_I = 5 \text{ V}$ , $I_O = 0.5 \text{ to } 100 \text{ mA}$		3	15	mV	
$I_d$	Quiescent current	$V_I = 5 \text{ to } 18\text{V}$ , $I_O = 0\text{mA}$	ON MODE		0.5	1	mA
		$V_I = 5 \text{ to } 18\text{V}$ , $I_O = 100\text{mA}$			1.5	3	
		$V_I = 6 \text{ V}$	OFF MODE		50	100	$\mu\text{A}$
SVR	Supply voltage rejection	$I_O = 5 \text{ mA}$ , $V_I = 6 \pm 1 \text{ V}$	$f = 120 \text{ Hz}$		78	dB	
			$f = 1 \text{ kHz}$		73		
			$f = 10 \text{ kHz}$		60		
eN	Output noise voltage	$B = 10 \text{ Hz to } 100 \text{ kHz}$		50		$\mu\text{V}$	
$V_d$	Dropout voltage	$I_O = 100 \text{ mA}$		0.2	0.4	V	
		$I_O = 100 \text{ mA}$ , $T_A = -40 \text{ to } 125^\circ\text{C}$			0.5		
$V_{IL}$	Control input logic low	$T_A = -40 \text{ to } 125^\circ\text{C}$			0.8	V	
$V_{IH}$	Control input logic high	$T_A = -40 \text{ to } 125^\circ\text{C}$	2			V	
$I_I$	Control input current	$V_I = 6 \text{ V}$ , $V_C = 6 \text{ V}$		10		$\mu\text{A}$	
$C_O$	Output bypass capacitance	$\text{ESR} = 0.1 \text{ to } 10 \Omega$ , $I_O = 0 \text{ to } 100 \text{ mA}$	2	10		$\mu\text{F}$	

**Table 17. Electrical characteristics for LE40C** (refer to the test circuits,  $T_J = 25^\circ\text{C}$ ,  $C_I = 0.1 \mu\text{F}$ ,  $C_O = 2.2 \mu\text{F}$  unless otherwise specified.)

Symbol	Parameter	Test conditions	Min.	Typ.	Max.	Unit	
$V_O$	Output voltage	$I_O = 10 \text{ mA}$ , $V_I = 6 \text{ V}$	3.92	4	4.08	V	
		$I_O = 10 \text{ mA}$ , $V_I = 6 \text{ V}$ , $T_A = -25 \text{ to } 85^\circ\text{C}$	3.84		4.16		
$V_I$	Operating input voltage	$I_O = 100 \text{ mA}$			18	V	
$I_O$	Output current limit		150			mA	
$\Delta V_O$	Line regulation	$V_I = 4.7 \text{ to } 18 \text{ V}$ , $I_O = 0.5 \text{ mA}$		4	30	mV	
$\Delta V_O$	Load regulation	$V_I = 5 \text{ V}$ , $I_O = 0.5 \text{ to } 100 \text{ mA}$		3	25	mV	
$I_d$	Quiescent current	$V_I = 5 \text{ to } 18\text{V}$ , $I_O = 0\text{mA}$	ON MODE		0.5	1	mA
		$V_I = 5 \text{ to } 18\text{V}$ , $I_O = 100\text{mA}$			1.5	3	
		$V_I = 6 \text{ V}$	OFF MODE		50	100	$\mu\text{A}$
SVR	Supply voltage rejection	$I_O = 5 \text{ mA}$ , $V_I = 6 \pm 1 \text{ V}$	$f = 120 \text{ Hz}$		78	dB	
			$f = 1 \text{ kHz}$		73		
			$f = 10 \text{ kHz}$		60		
eN	Output noise voltage	$B = 10 \text{ Hz to } 100 \text{ kHz}$		50		$\mu\text{V}$	
$V_d$	Dropout voltage	$I_O = 100 \text{ mA}$		0.2	0.4	V	
		$I_O = 100 \text{ mA}$ , $T_A = -40 \text{ to } 125^\circ\text{C}$			0.5		
$V_{IL}$	Control input logic low	$T_A = -40 \text{ to } 125^\circ\text{C}$			0.8	V	
$V_{IH}$	Control input logic high	$T_A = -40 \text{ to } 125^\circ\text{C}$	2			V	
$I_I$	Control input current	$V_I = 6 \text{ V}$ , $V_C = 6 \text{ V}$		10		$\mu\text{A}$	
$C_O$	Output bypass capacitance	$\text{ESR} = 0.1 \text{ to } 10 \Omega$ , $I_O = 0 \text{ to } 100 \text{ mA}$	2	10		$\mu\text{F}$	

**Table 18. Electrical characteristics for LE45AB** (refer to the test circuits,  $T_J = 25^\circ\text{C}$ ,  $C_I = 0.1 \mu\text{F}$ ,  $C_O = 2.2 \mu\text{F}$  unless otherwise specified.)

Symbol	Parameter	Test conditions	Min.	Typ.	Max.	Unit	
$V_O$	Output voltage	$I_O = 10 \text{ mA}$ , $V_I = 6.5 \text{ V}$	4.445	4.5	4.545	V	
		$I_O = 10 \text{ mA}$ , $V_I = 6.5 \text{ V}$ , $T_A = -25 \text{ to } 85^\circ\text{C}$	4.41		4.59		
$V_I$	Operating input voltage	$I_O = 100 \text{ mA}$			18	V	
$I_O$	Output current limit		150			mA	
$\Delta V_O$	Line regulation	$V_I = 5.2 \text{ to } 18 \text{ V}$ , $I_O = 0.5 \text{ mA}$		4	20	mV	
$\Delta V_O$	Load regulation	$V_I = 5.5 \text{ V}$ , $I_O = 0.5 \text{ to } 100 \text{ mA}$		3	15	mV	
$I_d$	Quiescent current	$V_I = 5.5 \text{ to } 18 \text{ V}$ , $I_O = 0 \text{ mA}$	ON MODE		0.5	1	mA
		$V_I = 5.5 \text{ to } 18 \text{ V}$ , $I_O = 100 \text{ mA}$			1.5	3	
		$V_I = 6 \text{ V}$	OFF MODE		50	100	$\mu\text{A}$
SVR	Supply voltage rejection	$I_O = 5 \text{ mA}$ , $V_I = 6.5 \pm 1 \text{ V}$	$f = 120 \text{ Hz}$		77	dB	
			$f = 1 \text{ kHz}$		72		
			$f = 10 \text{ kHz}$		60		
eN	Output noise voltage	$B = 10 \text{ Hz to } 100 \text{ kHz}$		50		$\mu\text{V}$	
$V_d$	Dropout voltage	$I_O = 100 \text{ mA}$		0.2	0.4	V	
		$I_O = 100 \text{ mA}$ , $T_A = -40 \text{ to } 125^\circ\text{C}$			0.5		
$V_{IL}$	Control input logic low	$T_A = -40 \text{ to } 125^\circ\text{C}$			0.8	V	
$V_{IH}$	Control input logic high	$T_A = -40 \text{ to } 125^\circ\text{C}$	2			V	
$I_I$	Control input current	$V_I = 6 \text{ V}$ , $V_C = 6 \text{ V}$		10		$\mu\text{A}$	
$C_O$	Output bypass capacitance	$\text{ESR} = 0.1 \text{ to } 10 \Omega$ , $I_O = 0 \text{ to } 100 \text{ mA}$	2	10		$\mu\text{F}$	

**Table 19. Electrical characteristics for LE45C** (refer to the test circuits,  $T_J = 25^\circ\text{C}$ ,  $C_I = 0.1 \mu\text{F}$ ,  $C_O = 2.2 \mu\text{F}$  unless otherwise specified.)

Symbol	Parameter	Test conditions	Min.	Typ.	Max.	Unit	
$V_O$	Output voltage	$I_O = 10 \text{ mA}$ , $V_I = 6.5 \text{ V}$	4.41	4.5	4.59	V	
		$I_O = 10 \text{ mA}$ , $V_I = 6.5 \text{ V}$ , $T_A = -25 \text{ to } 85^\circ\text{C}$	4.32		4.68		
$V_I$	Operating input voltage	$I_O = 100 \text{ mA}$			18	V	
$I_O$	Output current limit		150			mA	
$\Delta V_O$	Line regulation	$V_I = 5.2 \text{ to } 18 \text{ V}$ , $I_O = 0.5 \text{ mA}$		4	30	mV	
$\Delta V_O$	Load regulation	$V_I = 5.5 \text{ V}$ , $I_O = 0.5 \text{ to } 100 \text{ mA}$		3	25	mV	
$I_d$	Quiescent current	$V_I = 5.5 \text{ to } 18 \text{ V}$ , $I_O = 0 \text{ mA}$	ON MODE		0.5	1	mA
		$V_I = 5.5 \text{ to } 18 \text{ V}$ , $I_O = 100 \text{ mA}$			1.5	3	
		$V_I = 6 \text{ V}$	OFF MODE		50	100	$\mu\text{A}$
SVR	Supply voltage rejection	$I_O = 5 \text{ mA}$ , $V_I = 6.5 \pm 1 \text{ V}$	$f = 120 \text{ Hz}$		77	dB	
			$f = 1 \text{ kHz}$		72		
			$f = 10 \text{ kHz}$		60		
eN	Output noise voltage	$B = 10 \text{ Hz to } 100 \text{ kHz}$		50		$\mu\text{V}$	
$V_d$	Dropout voltage	$I_O = 100 \text{ mA}$		0.2	0.4	V	
		$I_O = 100 \text{ mA}$ , $T_A = -40 \text{ to } 125^\circ\text{C}$			0.5		
$V_{IL}$	Control input logic low	$T_A = -40 \text{ to } 125^\circ\text{C}$			0.8	V	
$V_{IH}$	Control input logic high	$T_A = -40 \text{ to } 125^\circ\text{C}$	2			V	
$I_I$	Control input current	$V_I = 6 \text{ V}$ , $V_C = 6 \text{ V}$		10		$\mu\text{A}$	
$C_O$	Output bypass capacitance	$\text{ESR} = 0.1 \text{ to } 10 \Omega$ , $I_O = 0 \text{ to } 100 \text{ mA}$	2	10		$\mu\text{F}$	

**Table 20. Electrical characteristics for LE47AB** (refer to the test circuits,  $T_J = 25^\circ\text{C}$ ,  $C_I = 0.1 \mu\text{F}$ ,  $C_O = 2.2 \mu\text{F}$  unless otherwise specified.)

Symbol	Parameter	Test conditions	Min.	Typ.	Max.	Unit	
$V_O$	Output voltage	$I_O = 10 \text{ mA}$ , $V_I = 6.7 \text{ V}$	4.653	4.7	4.747	V	
		$I_O = 10 \text{ mA}$ , $V_I = 6.7 \text{ V}$ , $T_A = -25 \text{ to } 85^\circ\text{C}$	4.606		4.794		
$V_I$	Operating input voltage	$I_O = 100 \text{ mA}$			18	V	
$I_O$	Output current limit		150			mA	
$\Delta V_O$	Line regulation	$V_I = 5.4 \text{ to } 18 \text{ V}$ , $I_O = 0.5 \text{ mA}$		4	20	mV	
$\Delta V_O$	Load regulation	$V_I = 5.7 \text{ V}$ , $I_O = 0.5 \text{ to } 100 \text{ mA}$		3	15	mV	
$I_d$	Quiescent current	$V_I = 5.7 \text{ to } 18 \text{ V}$ , $I_O = 0 \text{ mA}$	ON MODE		0.5	1	mA
		$V_I = 5.7 \text{ to } 18 \text{ V}$ , $I_O = 100 \text{ mA}$			1.5	3	
		$V_I = 6 \text{ V}$	OFF MODE		50	100	$\mu\text{A}$
SVR	Supply voltage rejection	$I_O = 5 \text{ mA}$ , $V_I = 6.7 \pm 1 \text{ V}$	$f = 120 \text{ Hz}$		77	dB	
			$f = 1 \text{ kHz}$		72		
			$f = 10 \text{ kHz}$		60		
eN	Output noise voltage	$B = 10 \text{ Hz to } 100 \text{ kHz}$		50		$\mu\text{V}$	
$V_d$	Dropout voltage	$I_O = 100 \text{ mA}$		0.2	0.4	V	
		$I_O = 100 \text{ mA}$ , $T_A = -40 \text{ to } 125^\circ\text{C}$			0.5		
$V_{IL}$	Control input logic low	$T_A = -40 \text{ to } 125^\circ\text{C}$			0.8	V	
$V_{IH}$	Control input logic high	$T_A = -40 \text{ to } 125^\circ\text{C}$	2			V	
$I_I$	Control input current	$V_I = 6 \text{ V}$ , $V_C = 6 \text{ V}$		10		$\mu\text{A}$	
$C_O$	Output bypass capacitance	$\text{ESR} = 0.1 \text{ to } 10 \Omega$ , $I_O = 0 \text{ to } 100 \text{ mA}$	2	10		$\mu\text{F}$	



**Table 21. Electrical characteristics for LE47C** (refer to the test circuits,  $T_J = 25^\circ\text{C}$ ,  $C_I = 0.1 \mu\text{F}$ ,  $C_O = 2.2 \mu\text{F}$  unless otherwise specified.)

Symbol	Parameter	Test conditions	Min.	Typ.	Max.	Unit	
$V_O$	Output voltage	$I_O = 10 \text{ mA}$ , $V_I = 6.7 \text{ V}$	4.606	4.7	4.794	V	
		$I_O = 10 \text{ mA}$ , $V_I = 6.7 \text{ V}$ , $T_A = -25 \text{ to } 85^\circ\text{C}$	4.512		4.888		
$V_I$	Operating input voltage	$I_O = 100 \text{ mA}$			18	V	
$I_O$	Output current limit		150			mA	
$\Delta V_O$	Line regulation	$V_I = 5.4 \text{ to } 18 \text{ V}$ , $I_O = 0.5 \text{ mA}$		4	30	mV	
$\Delta V_O$	Load regulation	$V_I = 5.7 \text{ V}$ , $I_O = 0.5 \text{ to } 100 \text{ mA}$		3	25	mV	
$I_d$	Quiescent current	$V_I = 5.7 \text{ to } 18 \text{ V}$ , $I_O = 0 \text{ mA}$	ON MODE		0.5	1	mA
		$V_I = 5.7 \text{ to } 18 \text{ V}$ , $I_O = 100 \text{ mA}$			1.5	3	
		$V_I = 6 \text{ V}$	OFF MODE		50	100	$\mu\text{A}$
SVR	Supply voltage rejection	$I_O = 5 \text{ mA}$ , $V_I = 6.7 \pm 1 \text{ V}$	$f = 120 \text{ Hz}$		77	dB	
			$f = 1 \text{ kHz}$		72		
			$f = 10 \text{ kHz}$		60		
eN	Output noise voltage	$B = 10 \text{ Hz to } 100 \text{ kHz}$		50		$\mu\text{V}$	
$V_d$	Dropout voltage	$I_O = 100 \text{ mA}$		0.2	0.4	V	
		$I_O = 100 \text{ mA}$ , $T_A = -40 \text{ to } 125^\circ\text{C}$			0.5		
$V_{IL}$	Control input logic low	$T_A = -40 \text{ to } 125^\circ\text{C}$			0.8	V	
$V_{IH}$	Control input logic high	$T_A = -40 \text{ to } 125^\circ\text{C}$	2			V	
$I_I$	Control input current	$V_I = 6 \text{ V}$ , $V_C = 6 \text{ V}$		10		$\mu\text{A}$	
$C_O$	Output bypass capacitance	$\text{ESR} = 0.1 \text{ to } 10 \Omega$ , $I_O = 0 \text{ to } 100 \text{ mA}$	2	10		$\mu\text{F}$	

**Table 22. Electrical characteristics for LE50AB** (refer to the test circuits,  $T_J = 25^\circ\text{C}$ ,  $C_I = 0.1 \mu\text{F}$ ,  $C_O = 2.2 \mu\text{F}$  unless otherwise specified.)

Symbol	Parameter	Test conditions	Min.	Typ.	Max.	Unit	
$V_O$	Output voltage	$I_O = 10 \text{ mA}$ , $V_I = 7 \text{ V}$	4.95	5	5.05	V	
		$I_O = 10 \text{ mA}$ , $V_I = 7 \text{ V}$ , $T_A = -25 \text{ to } 85^\circ\text{C}$	4.9		5.1		
$V_I$	Operating input voltage	$I_O = 100 \text{ mA}$			18	V	
$I_O$	Output current limit		150	350	425	mA	
$\Delta V_O$	Line regulation	$V_I = 5.7 \text{ to } 18 \text{ V}$ , $I_O = 0.5 \text{ mA}$		4	20	mV	
$\Delta V_O$	Load regulation	$V_I = 6 \text{ V}$ , $I_O = 0.5 \text{ to } 100 \text{ mA}$		3	15	mV	
$I_d$	Quiescent current	$V_I = 6 \text{ to } 18\text{V}$ , $I_O = 0\text{mA}$	ON MODE		0.5	1	mA
		$V_I = 6 \text{ to } 18\text{V}$ , $I_O = 100\text{mA}$			1.5	3	
		$V_I = 6 \text{ V}$	OFF MODE		50	100	$\mu\text{A}$
SVR	Supply voltage rejection	$I_O = 5 \text{ mA}$ , $V_I = 7 \pm 1 \text{ V}$	$f = 120 \text{ Hz}$		76	dB	
			$f = 1 \text{ kHz}$		71		
			$f = 10 \text{ kHz}$		60		
eN	Output noise voltage	$B = 10 \text{ Hz to } 100 \text{ kHz}$		50		$\mu\text{V}$	
$V_d$	Dropout voltage	$I_O = 100 \text{ mA}$		0.2	0.4	V	
		$I_O = 100 \text{ mA}$ , $T_A = -40 \text{ to } 125^\circ\text{C}$			0.5		
$V_{IL}$	Control input logic low	$T_A = -40 \text{ to } 125^\circ\text{C}$			0.8	V	
$V_{IH}$	Control input logic high	$T_A = -40 \text{ to } 125^\circ\text{C}$	2			V	
$I_I$	Control input current	$V_I = 6 \text{ V}$ , $V_C = 6 \text{ V}$		10		$\mu\text{A}$	
$C_O$	Output bypass capacitance	$\text{ESR} = 0.1 \text{ to } 10 \Omega$ , $I_O = 0 \text{ to } 100 \text{ mA}$	2	10		$\mu\text{F}$	

**Table 23. Electrical characteristics for LE50C** (refer to the test circuits,  $T_J = 25^\circ\text{C}$ ,  $C_I = 0.1 \mu\text{F}$ ,  $C_O = 2.2 \mu\text{F}$  unless otherwise specified.)

Symbol	Parameter	Test conditions	Min.	Typ.	Max.	Unit	
$V_O$	Output voltage	$I_O = 10 \text{ mA}$ , $V_I = 7 \text{ V}$	4.9	5	5.1	V	
		$I_O = 10 \text{ mA}$ , $V_I = 7 \text{ V}$ , $T_A = -25 \text{ to } 85^\circ\text{C}$	4.8		5.2		
$V_I$	Operating input voltage	$I_O = 100 \text{ mA}$			18	V	
$I_O$	Output current limit		150	350	425	mA	
$\Delta V_O$	Line regulation	$V_I = 5.7 \text{ to } 18 \text{ V}$ , $I_O = 0.5 \text{ mA}$		4	30	mV	
$\Delta V_O$	Load regulation	$V_I = 6 \text{ V}$ , $I_O = 0.5 \text{ to } 100 \text{ mA}$		3	25	mV	
$I_d$	Quiescent current	$V_I = 6 \text{ to } 18\text{V}$ , $I_O = 0\text{mA}$	ON MODE		0.5	1	mA
		$V_I = 6 \text{ to } 18\text{V}$ , $I_O = 100\text{mA}$			1.5	3	
		$V_I = 6 \text{ V}$	OFF MODE		50	100	$\mu\text{A}$
SVR	Supply voltage rejection	$I_O = 5 \text{ mA}$ , $V_I = 7 \pm 1 \text{ V}$	$f = 120 \text{ Hz}$		76	dB	
			$f = 1 \text{ kHz}$		71		
			$f = 10 \text{ kHz}$		60		
eN	Output noise voltage	$B = 10 \text{ Hz to } 100 \text{ kHz}$		50		$\mu\text{V}$	
$V_d$	Dropout voltage	$I_O = 100 \text{ mA}$		0.2	0.4	V	
		$I_O = 100 \text{ mA}$ , $T_A = -40 \text{ to } 125^\circ\text{C}$			0.5		
$V_{IL}$	Control input logic low	$T_A = -40 \text{ to } 125^\circ\text{C}$			0.8	V	
$V_{IH}$	Control input logic high	$T_A = -40 \text{ to } 125^\circ\text{C}$	2			V	
$I_I$	Control input current	$V_I = 6 \text{ V}$ , $V_C = 6 \text{ V}$		10		$\mu\text{A}$	
$C_O$	Output bypass capacitance	$\text{ESR} = 0.1 \text{ to } 10 \Omega$ , $I_O = 0 \text{ to } 100 \text{ mA}$	2	10		$\mu\text{F}$	

**Table 24. Electrical characteristics for LE80AB** (refer to the test circuits,  $T_J = 25^\circ\text{C}$ ,  $C_I = 0.1 \mu\text{F}$ ,  $C_O = 2.2 \mu\text{F}$  unless otherwise specified.)

Symbol	Parameter	Test conditions	Min.	Typ.	Max.	Unit	
$V_O$	Output voltage	$I_O = 10 \text{ mA}$ , $V_I = 10 \text{ V}$	7.92	8	8.08	V	
		$I_O = 10 \text{ mA}$ , $V_I = 10 \text{ V}$ , $T_A = -25 \text{ to } 85^\circ\text{C}$	7.84		8.16		
$V_I$	Operating input voltage	$I_O = 100 \text{ mA}$			18	V	
$I_O$	Output current limit		150			mA	
$\Delta V_O$	Line regulation	$V_I = 8.7 \text{ to } 18 \text{ V}$ , $I_O = 0.5 \text{ mA}$		5	25	mV	
$\Delta V_O$	Load regulation	$V_I = 9 \text{ V}$ , $I_O = 0.5 \text{ to } 100 \text{ mA}$		3	15	mV	
$I_d$	Quiescent current	$V_I = 9 \text{ to } 18\text{V}$ , $I_O = 0\text{mA}$	ON MODE		0.7	1.6	mA
		$V_I = 9 \text{ to } 18\text{V}$ , $I_O = 100\text{mA}$			1.7	3.6	
		$V_I = 9 \text{ V}$	OFF MODE		70	140	$\mu\text{A}$
SVR	Supply voltage rejection	$I_O = 5 \text{ mA}$ , $V_I = 10 \pm 1 \text{ V}$	$f = 120 \text{ Hz}$		72	dB	
			$f = 1 \text{ kHz}$		66		
			$f = 10 \text{ kHz}$		57		
eN	Output noise voltage	$B = 10 \text{ Hz to } 100 \text{ kHz}$		50		$\mu\text{V}$	
$V_d$	Dropout voltage	$I_O = 100 \text{ mA}$		0.2	0.4	V	
		$I_O = 100 \text{ mA}$ , $T_A = -40 \text{ to } 125^\circ\text{C}$			0.5		
$V_{IL}$	Control input logic low	$T_A = -40 \text{ to } 125^\circ\text{C}$			0.8	V	
$V_{IH}$	Control input logic high	$T_A = -40 \text{ to } 125^\circ\text{C}$	2			V	
$I_I$	Control input current	$V_I = 9 \text{ V}$ , $V_C = 6 \text{ V}$		10		$\mu\text{A}$	
$C_O$	Output bypass capacitance	$\text{ESR} = 0.1 \text{ to } 10 \Omega$ , $I_O = 0 \text{ to } 100 \text{ mA}$	2	10		$\mu\text{F}$	

**Table 25. Electrical characteristics for LE80C** (refer to the test circuits,  $T_J = 25^\circ\text{C}$ ,  $C_I = 0.1 \mu\text{F}$ ,  $C_O = 2.2 \mu\text{F}$  unless otherwise specified.)

Symbol	Parameter	Test conditions	Min.	Typ.	Max.	Unit
$V_O$	Output voltage	$I_O = 10 \text{ mA}$ , $V_I = 10 \text{ V}$	7.84	8	8.16	V
		$I_O = 10 \text{ mA}$ , $V_I = 10 \text{ V}$ , $T_A = -25 \text{ to } 85^\circ\text{C}$	7.68		8.32	
$V_I$	Operating input voltage	$I_O = 100 \text{ mA}$			18	V
$I_O$	Output current limit		150			mA
$\Delta V_O$	Line regulation	$V_I = 8.7 \text{ to } 18 \text{ V}$ , $I_O = 0.5 \text{ mA}$		5	35	mV
$\Delta V_O$	Load regulation	$V_I = 9 \text{ V}$ , $I_O = 0.5 \text{ to } 100 \text{ mA}$		3	25	mV
$I_d$	Quiescent current	$V_I = 9 \text{ to } 18\text{V}$ , $I_O = 0\text{mA}$	ON MODE	0.7	1.6	mA
		$V_I = 9 \text{ to } 18\text{V}$ , $I_O = 100\text{mA}$		1.7	3.6	
		$V_I = 9 \text{ V}$	OFF MODE	70	140	$\mu\text{A}$
SVR	Supply voltage rejection	$I_O = 5 \text{ mA}$ , $V_I = 10 \pm 1 \text{ V}$	$f = 120 \text{ Hz}$	72		dB
			$f = 1 \text{ kHz}$	66		
			$f = 10 \text{ kHz}$	57		
eN	Output noise voltage	$B = 10 \text{ Hz to } 100 \text{ kHz}$		50		$\mu\text{V}$
$V_d$	Dropout voltage	$I_O = 100 \text{ mA}$		0.2	0.4	V
		$I_O = 100 \text{ mA}$ , $T_A = -40 \text{ to } 125^\circ\text{C}$			0.5	
$V_{IL}$	Control input logic low	$T_A = -40 \text{ to } 125^\circ\text{C}$			0.8	V
$V_{IH}$	Control input logic high	$T_A = -40 \text{ to } 125^\circ\text{C}$	2			V
$I_I$	Control input current	$V_I = 9 \text{ V}$ , $V_C = 6 \text{ V}$		10		$\mu\text{A}$
$C_O$	Output bypass capacitance	$\text{ESR} = 0.1 \text{ to } 10 \Omega$ , $I_O = 0 \text{ to } 100 \text{ mA}$	2	10		$\mu\text{F}$

# 5 Typical performance characteristics

(unless otherwise specified  $V_{O(NOM)} = 3.3\text{ V}$ )

**Figure 4. Dropout voltage vs output current**      **Figure 5. Dropout voltage vs temperature**

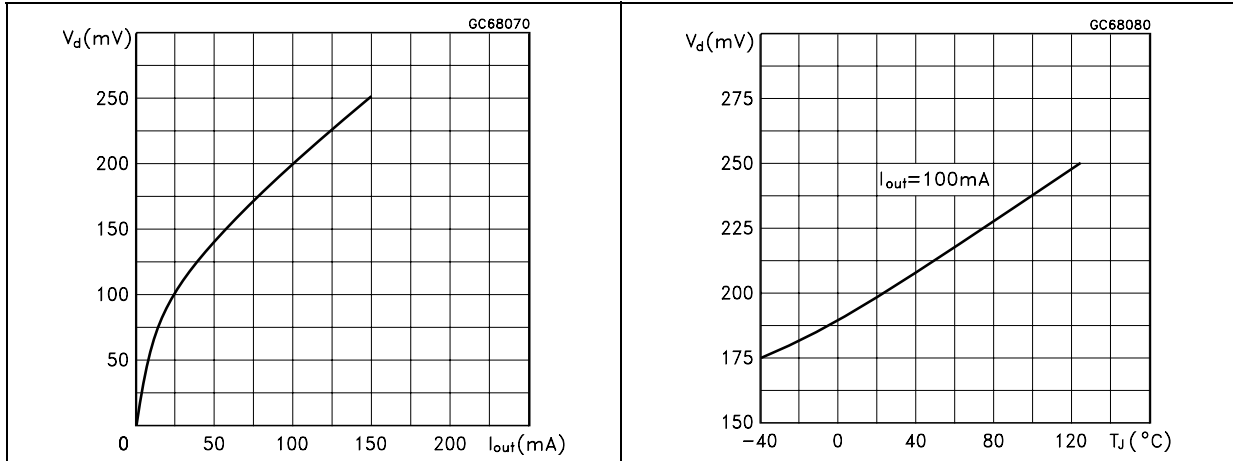

**Figure 6. Supply current vs temperature**      **Figure 7. Supply current vs input voltage**

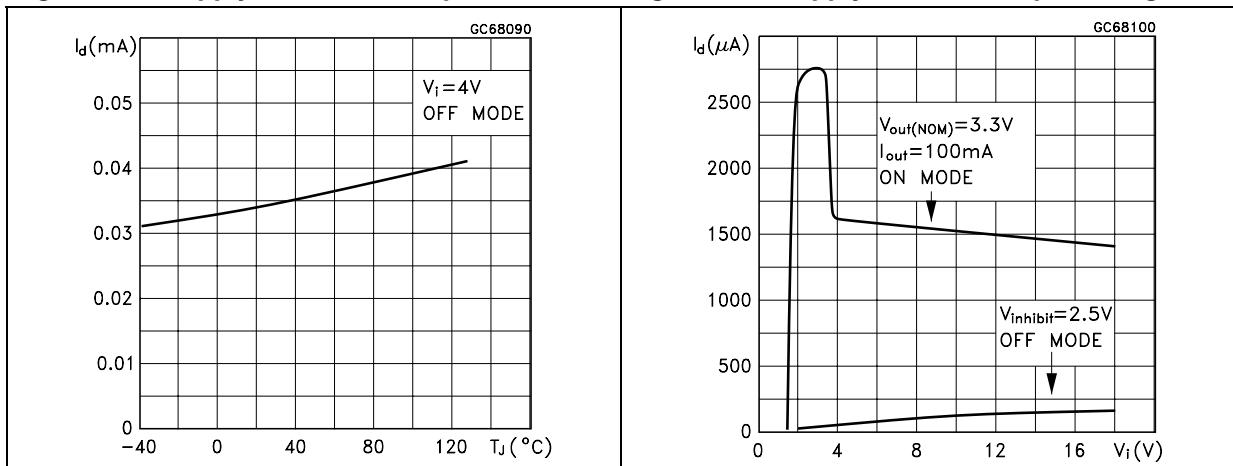

**Figure 8. Short circuit current vs dropout voltage**      **Figure 9. S.V.R. vs frequency**

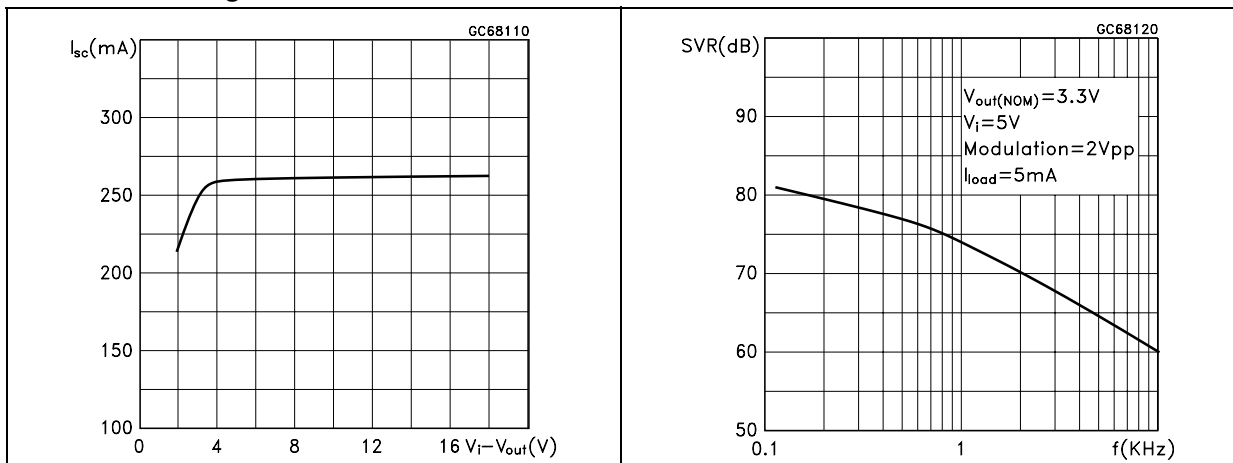

Figure 10. Logic controlled precision 3.3/5.0 V selectable output

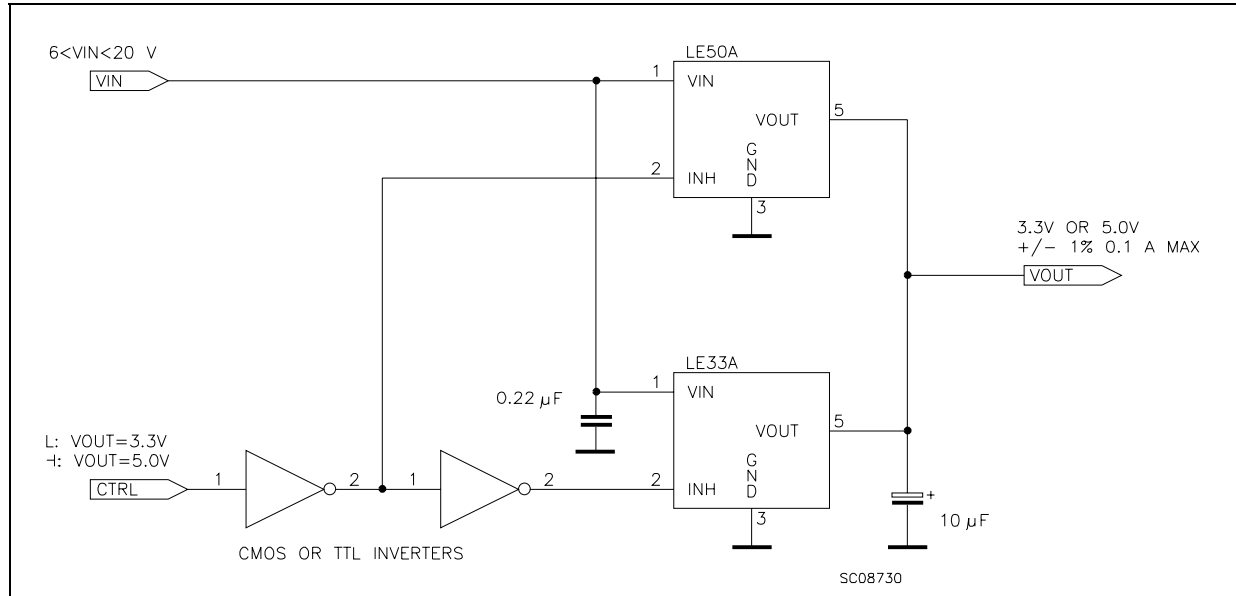

Figure 11. Sequential multi-output supply

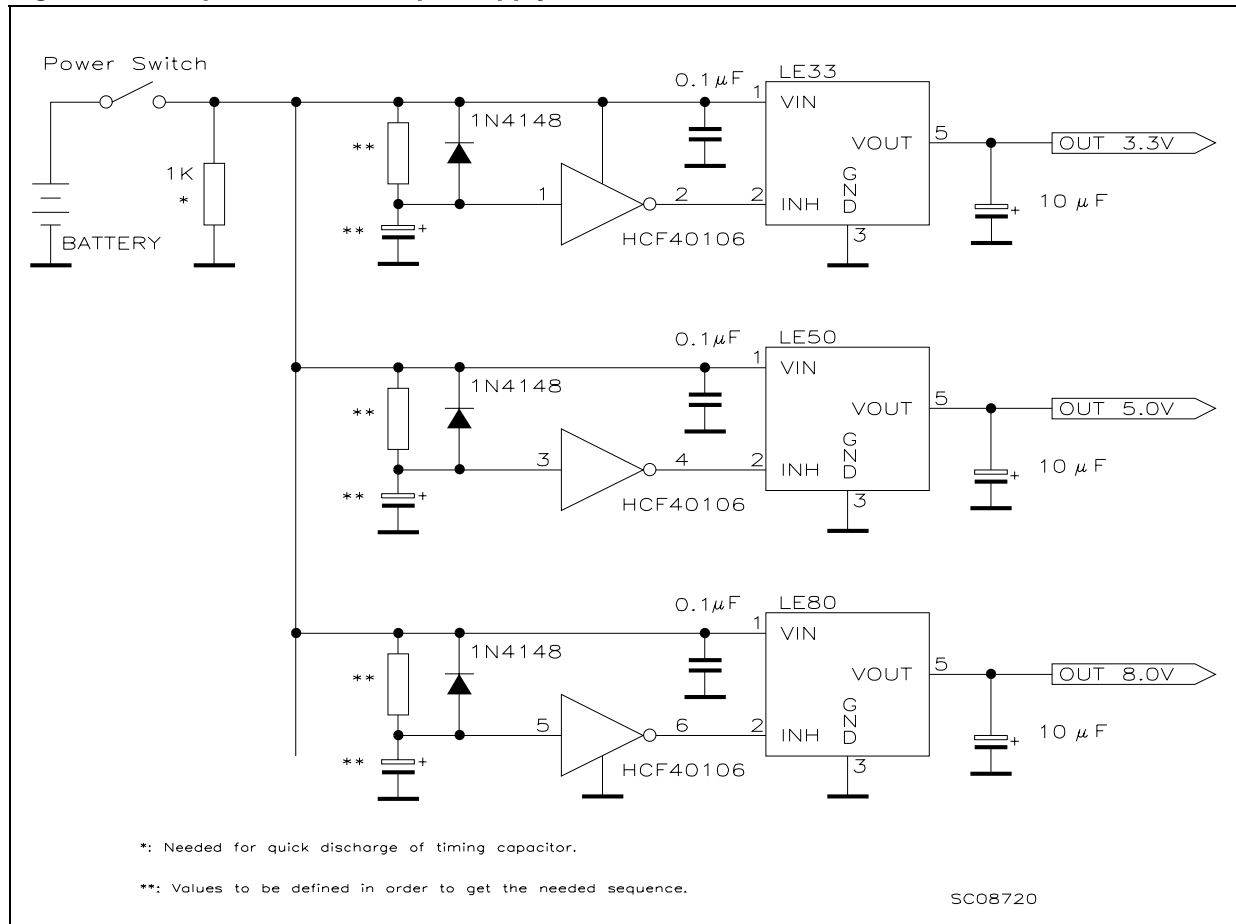

Figure 12. Multiple supply with ON/OFF toggle switch

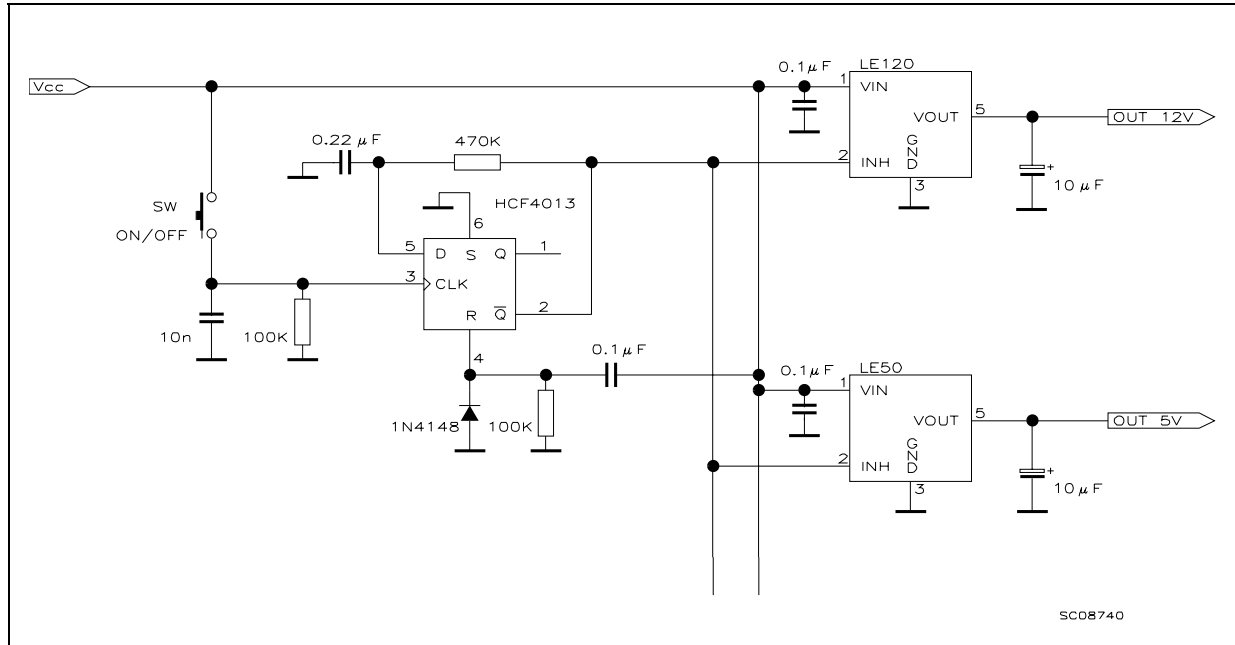
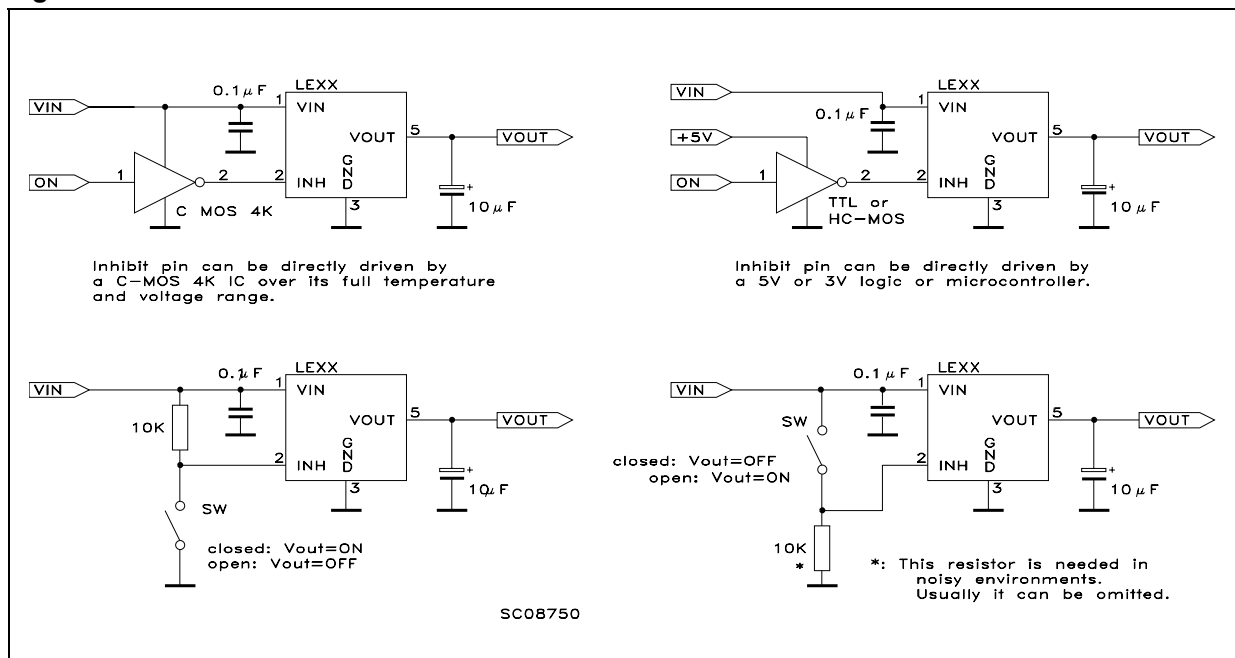

Figure 13. Basic inhibit functions





## 6 Package mechanical data

In order to meet environmental requirements, ST offers these devices in ECOPACK® packages. These packages have a Lead-free second level interconnect. The category of second Level Interconnect is marked on the package and on the inner box label, in compliance with JEDEC Standard JESD97. The maximum ratings related to soldering conditions are also marked on the inner box label. ECOPACK is an ST trademark. ECOPACK specifications are available at: [www.st.com](http://www.st.com).

**SO-8 mechanical data**

Dim.	mm.			inch.		
	Min.	Typ.	Max.	Min.	Typ.	Max.
A	1.35		1.75	0.053		0.069
A1	0.10		0.25	0.04		0.010
A2	1.10		1.65	0.043		0.065
B	0.33		0.51	0.013		0.020
C	0.19		0.25	0.007		0.010
D	4.80		5.00	0.189		0.197
E	3.80		4.00	0.150		0.157
e		1.27			0.050	
H	5.80		6.20	0.228		0.244
h	0.25		0.50	0.010		0.020
L	0.40		1.27	0.016		0.050
k	8° (max.)					
ddd			0.1			0.04

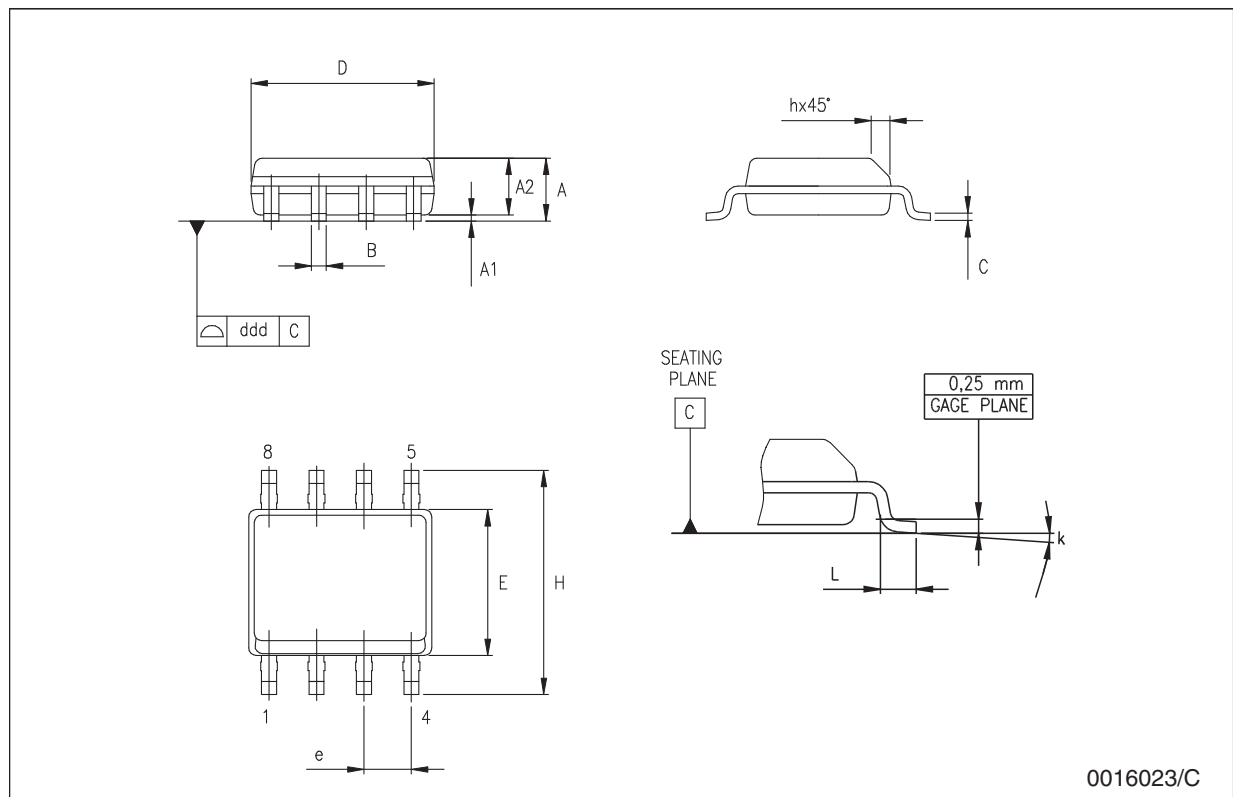

0016023/C

**TO-92 mechanical data**

Dim.	mm.			mils.		
	Min.	Typ.	Max.	Min.	Typ.	Max.
A	4.32		4.95	170.1		194.9
b	0.36		0.51	14.2		20.1
D	4.45		4.95	175.2		194.9
E	3.30		3.94	129.9		155.1
e	2.41		2.67	94.9		105.1
e1	1.14		1.40	44.9		55.1
L	12.7		15.49	500.0		609.8
R	2.16		2.41	85.0		94.9
S1	0.92		1.52	36.2		59.8
W	0.41		0.56	16.1		22.0
$\alpha$		5°			5°	

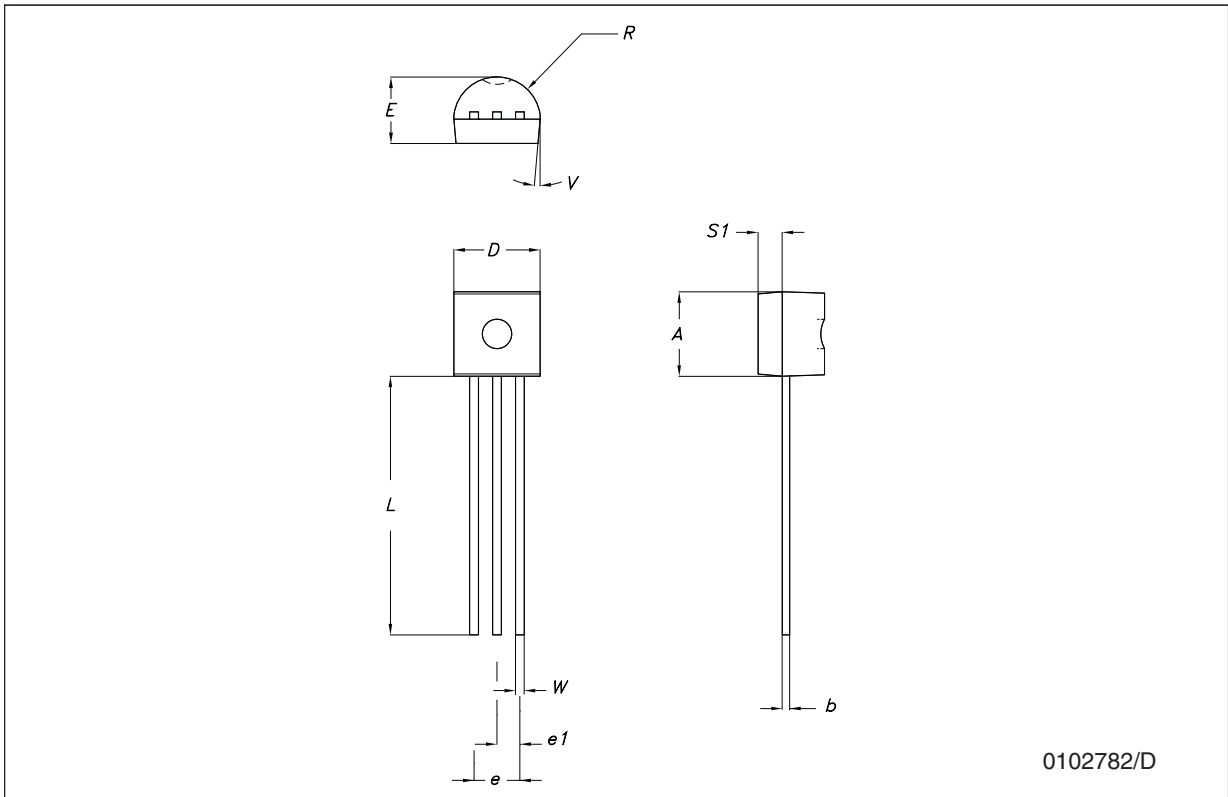

**Tape & reel SO-8 mechanical data**

Dim.	mm.			inch.		
	Min.	Typ.	Max.	Min.	Typ.	Max.
A			330			12.992
C	12.8		13.2	0.504		0.519
D	20.2			0.795		
N	60			2.362		
T			22.4			0.882
Ao	8.1		8.5	0.319		0.335
Bo	5.5		5.9	0.216		0.232
Ko	2.1		2.3	0.082		0.090
Po	3.9		4.1	0.153		0.161
P	7.9		8.1	0.311		0.319

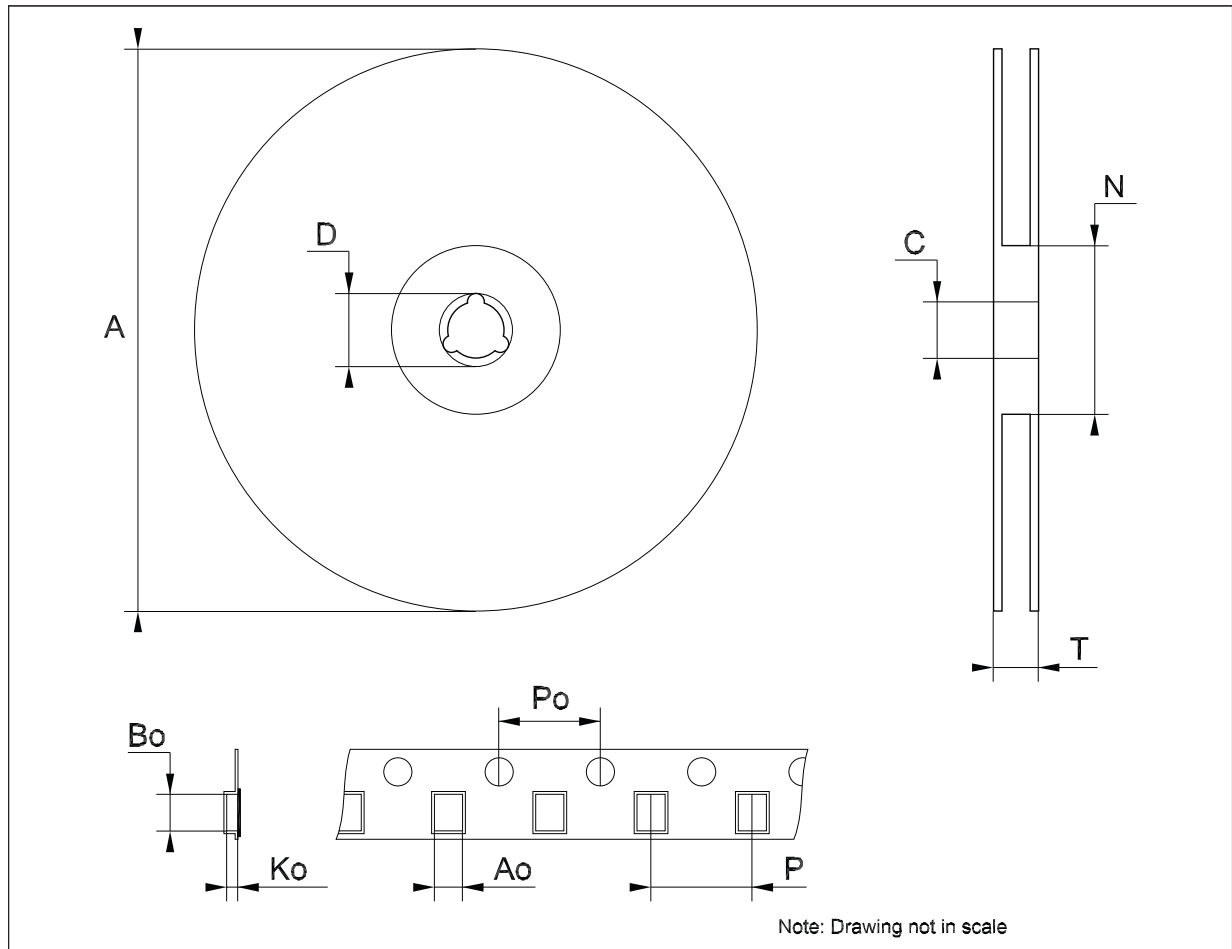

**Tape & reel for TO-92 mechanical data**

Dim.	mm.			inch.		
	Min.	Typ.	Max.	Min.	Typ.	Max.
A1		4.80			0.189	
T		3.80			0.150	
T1		1.60			0.063	
T2		2.30			0.091	
d		0.48			0.019	
P0	12.5		12.9	0.492		0.508
P2	5.65		7.05	0.222		0.278
F1, F2	2.44	2.54	2.94	0.096	0.100	0.116
delta H		±2			0.079	
W	17.5	18.00	19.0	0.689	0.709	0.748
W0	5.7		6.3	0.224		0.248
W1	8.5		9.25	0.335		0.364
W2		0.50			0.20	
H		18.50	18.70		0.728	0.726
H0	15.50		16.50	0.610		0.650
H1		25.00			0.984	
D0	3.8		4.2	0.150		0.165
t		0.90			0.035	
L1		3			0.118	
delta P		±1			0.039	
u		50			1.968	
Φ1		360			14.173	
Φ2		30			1.181	

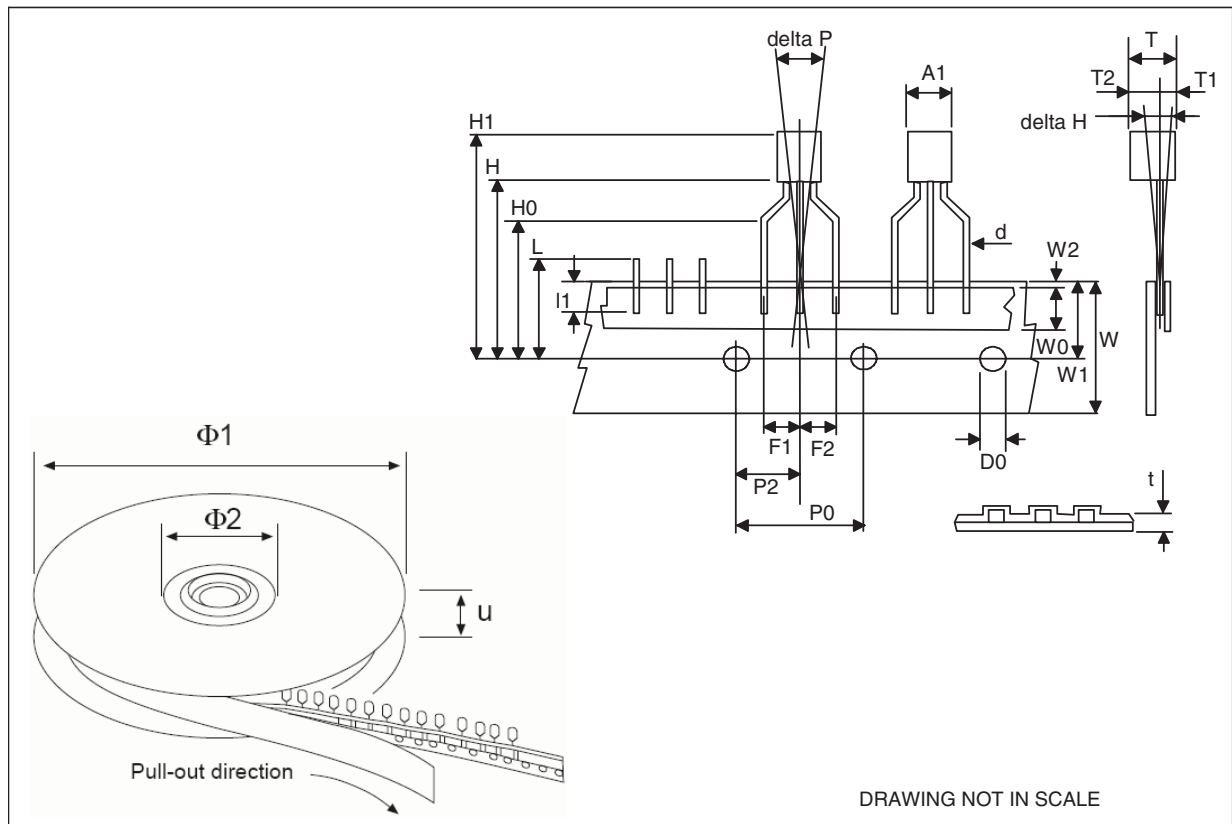

## 7 Order codes

Table 26. Order codes

Part numbers	Packages					Output voltage
	SO-8	SO-8 (T&R)	TO-92	TO-92 (T&R)	TO-92 (Ammopak)	
LE12AB		LE12ABD-TR <sup>(1)</sup>				1.25 V
LE12C			LE12CZ			1.25 V
LE25AB	LE25ABD	LE25ABD-TR <sup>(1)</sup>			LE25ABZ-AP <sup>(1)</sup>	2.5 V
LE25C		LE25CD-TR <sup>(1)</sup>		LE25CZ-TR <sup>(1)</sup>	LE25CZ-AP <sup>(1)</sup>	2.5 V
LE27AB	LE27ABD <sup>(1)</sup>	LE27ABD-TR <sup>(1)</sup>				2.7 V
LE27C	LE27CD <sup>(1)</sup>					2.7 V
LE30AB		LE30ABD-TR <sup>(1)</sup>		LE30ABZ-TR		3 V
LE30C	LE30CD	LE30CD-TR		LE30CZ-TR		3 V
LE33AB	LE33ABD		LE33ABZ	LE33ABZ-TR <sup>(1)</sup>	LE33ABZ-AP <sup>(1)</sup>	3.3 V
LE33C	LE33CD	LE33CD-TR	LE33CZ	LE33CZ-TR	LE33CZ-AP	3.3 V
LE35AB		LE35ABD-TR <sup>(1)</sup>	LE35ABZ <sup>(1)</sup>	LE35ABZ-TR <sup>(1)</sup>	LE35ABZ-AP <sup>(1)</sup>	3.5 V
LE35C	LE35CD <sup>(1)</sup>	LE35CD-TR <sup>(1)</sup>	LE35CZ	LE35CZ-TR <sup>(1)</sup>	LE35CZ-AP <sup>(1)</sup>	3.5 V
LE40AB		LE40ABD-TR <sup>(1)</sup>	LE40ABZ <sup>(1)</sup>	LE40ABZ-TR <sup>(1)</sup>	LE40ABZ-AP <sup>(1)</sup>	4 V
LE40C	LE40CD	LE40CD-TR <sup>(1)</sup>	LE40CZ	LE40CZ-TR <sup>(1)</sup>	LE40CZ-AP <sup>(1)</sup>	4 V
LE45AB		LE45ABD-TR			LE45ABZ-AP <sup>(1)</sup>	4.5 V
LE45C		LE45CD-TR			LE45CZ-AP <sup>(1)</sup>	4.5 V
LE47AB	LE47ABD <sup>(1)</sup>	LE47ABD-TR <sup>(1)</sup>	LE47ABZ	LE47ABZ-TR <sup>(1)</sup>	LE47ABZ-AP <sup>(1)</sup>	4.7 V
LE47C		LE47CD-TR <sup>(1)</sup>	LE47CZ <sup>(1)</sup>	LE47CZ-TR <sup>(1)</sup>	LE47CZ-AP <sup>(1)</sup>	4.7 V
LE50AB	LE50ABD	LE50ABD-TR	LE50ABZ	LE50ABZ-TR	LE50ABZ-AP	5 V
LE50C	LE50CD	LE50CD-TR	LE50CZ	LE50CZ-TR	LE50CZ-AP	5 V
LE55C			LE55CZ			5.5 V
LE80AB				LE80ABZ-TR <sup>(1)</sup>		8 V
LE80C		LE80CD-TR		LE80CZ-TR <sup>(1)</sup>		8 V

1. Available on request.

## 8 Revision history

**Table 27. Document revision history**

Date	Revision	Changes
09-Jul-2004	6	I <sub>O</sub> typ. and max. are changed in tab. 24 and 25 - pag. 14.
16-Mar-2005	7	Add Tape & Reel for TO-92 - Note on Table 3.
12-Feb-2007	8	Change value T <sub>OP</sub> on <a href="#">Table 2</a> .
26-Jul-2007	9	Add <a href="#">Table 1</a> in cover page.
29-Nov-2007	10	Modified: <a href="#">Table 26</a> .

**Please Read Carefully:**

Information in this document is provided solely in connection with ST products. STMicroelectronics NV and its subsidiaries ("ST") reserve the right to make changes, corrections, modifications or improvements, to this document, and the products and services described herein at any time, without notice.

All ST products are sold pursuant to ST's terms and conditions of sale.

Purchasers are solely responsible for the choice, selection and use of the ST products and services described herein, and ST assumes no liability whatsoever relating to the choice, selection or use of the ST products and services described herein.

No license, express or implied, by estoppel or otherwise, to any intellectual property rights is granted under this document. If any part of this document refers to any third party products or services it shall not be deemed a license grant by ST for the use of such third party products or services, or any intellectual property contained therein or considered as a warranty covering the use in any manner whatsoever of such third party products or services or any intellectual property contained therein.

**UNLESS OTHERWISE SET FORTH IN ST'S TERMS AND CONDITIONS OF SALE ST DISCLAIMS ANY EXPRESS OR IMPLIED WARRANTY WITH RESPECT TO THE USE AND/OR SALE OF ST PRODUCTS INCLUDING WITHOUT LIMITATION IMPLIED WARRANTIES OF MERCHANTABILITY, FITNESS FOR A PARTICULAR PURPOSE (AND THEIR EQUIVALENTS UNDER THE LAWS OF ANY JURISDICTION), OR INFRINGEMENT OF ANY PATENT, COPYRIGHT OR OTHER INTELLECTUAL PROPERTY RIGHT.**

**UNLESS EXPRESSLY APPROVED IN WRITING BY AN AUTHORIZED ST REPRESENTATIVE, ST PRODUCTS ARE NOT RECOMMENDED, AUTHORIZED OR WARRANTED FOR USE IN MILITARY, AIR CRAFT, SPACE, LIFE SAVING, OR LIFE SUSTAINING APPLICATIONS, NOR IN PRODUCTS OR SYSTEMS WHERE FAILURE OR MALFUNCTION MAY RESULT IN PERSONAL INJURY, DEATH, OR SEVERE PROPERTY OR ENVIRONMENTAL DAMAGE. ST PRODUCTS WHICH ARE NOT SPECIFIED AS "AUTOMOTIVE GRADE" MAY ONLY BE USED IN AUTOMOTIVE APPLICATIONS AT USER'S OWN RISK.**

Resale of ST products with provisions different from the statements and/or technical features set forth in this document shall immediately void any warranty granted by ST for the ST product or service described herein and shall not create or extend in any manner whatsoever, any liability of ST.

ST and the ST logo are trademarks or registered trademarks of ST in various countries.

Information in this document supersedes and replaces all information previously supplied.

The ST logo is a registered trademark of STMicroelectronics. All other names are the property of their respective owners.

© 2007 STMicroelectronics - All rights reserved

STMicroelectronics group of companies

Australia - Belgium - Brazil - Canada - China - Czech Republic - Finland - France - Germany - Hong Kong - India - Israel - Italy - Japan - Malaysia - Malta - Morocco - Singapore - Spain - Sweden - Switzerland - United Kingdom - United States of America

[www.st.com](http://www.st.com)